



CREATING
VALUE

COMPRESSED AIR SYSTEM

JOYGLOBAL

COMPRESSED AIR SYSTEM

COMPRESSED AIR SYSTEM

- Theory of Operation
- Component Descriptions
- Circuit Descriptions
- Settings and Adjustments
- Troubleshooting
- Removal and Installation

THEORY OF OPERATION

SEE SCHEMATICS BOOK

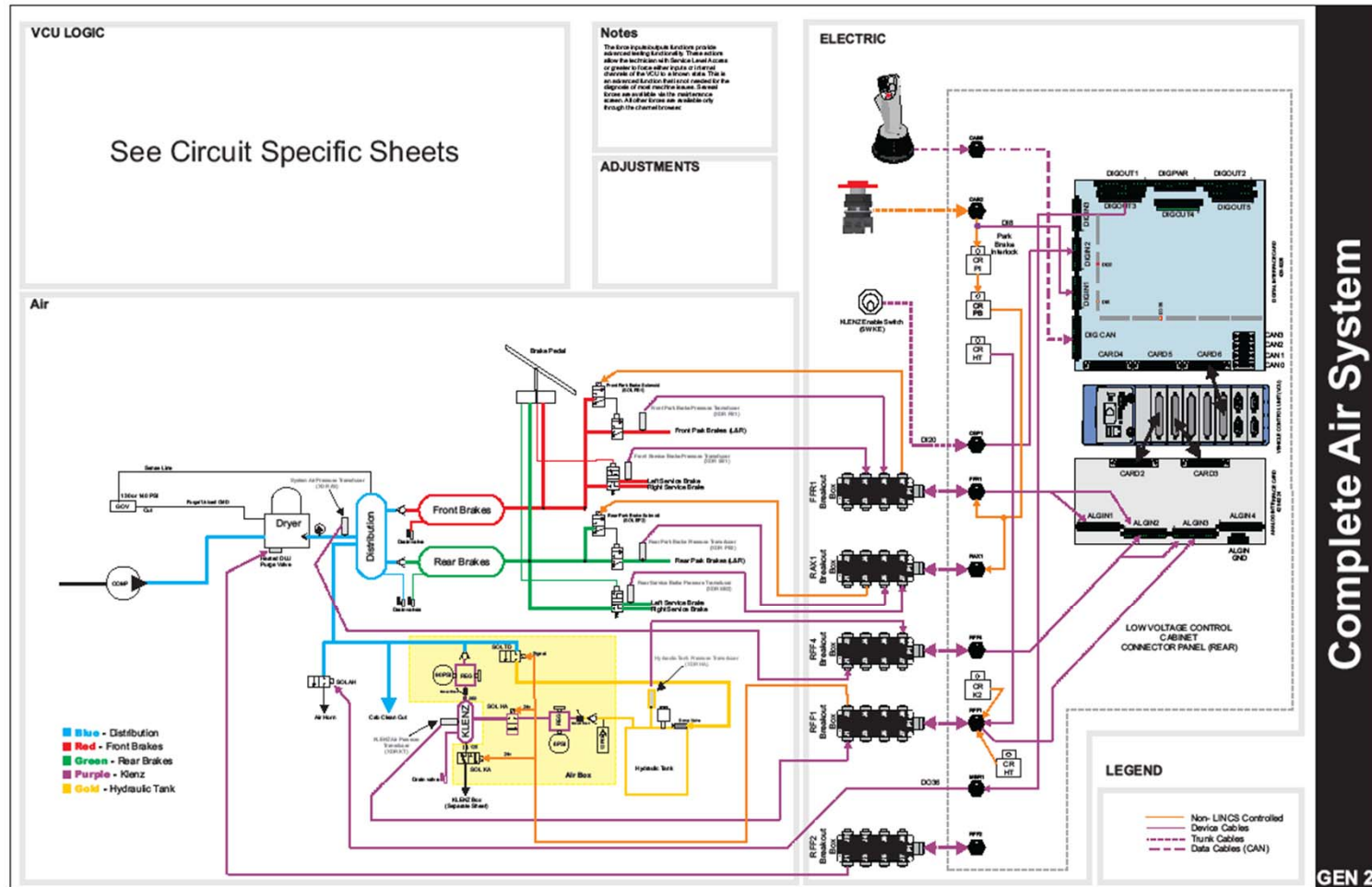

COMPONENT DESCRIPTIONS

COMPONENT DESCRIPTIONS

- Compressors
- Valves
- Tanks
- Solenoids
- Transducers

AIR COMPRESSOR RATINGS

Model	Displacement (CFM) at 1250 RPM	Displacement (CFM) at 1900 RPM (120psi)	Displacement (CFM) at 1900 RPM (140psi)	Allowable inlet Temp °f	Allowable outlet Temp. °f	Boosted CFM at 1900RPM (120psi)	Lubrication	Cooling
750	16.5	11.7	10	250	400	34	Engine oil	Coolant
922	31.7	27.8	23.8	170	350	NA	PTO	Coolant
550	13.2	NA	NA	250	400	NA	Engine	Coolant

BENDIX TU-FLO 750 COMPRESSOR

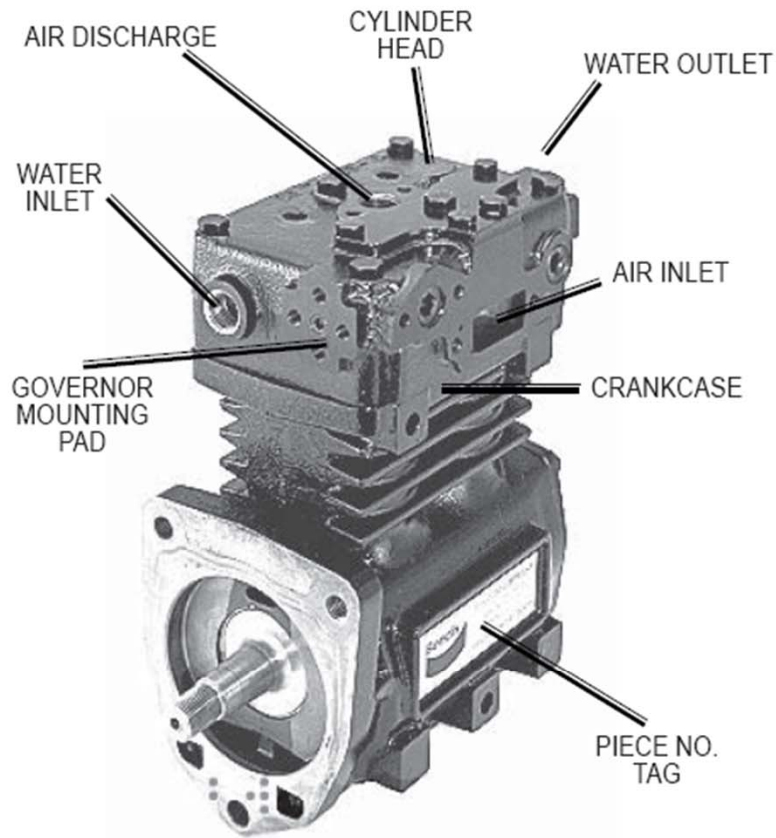

BENDIX® TU-FLO® 750 AIR COMPRESSOR
(EXTERIOR)

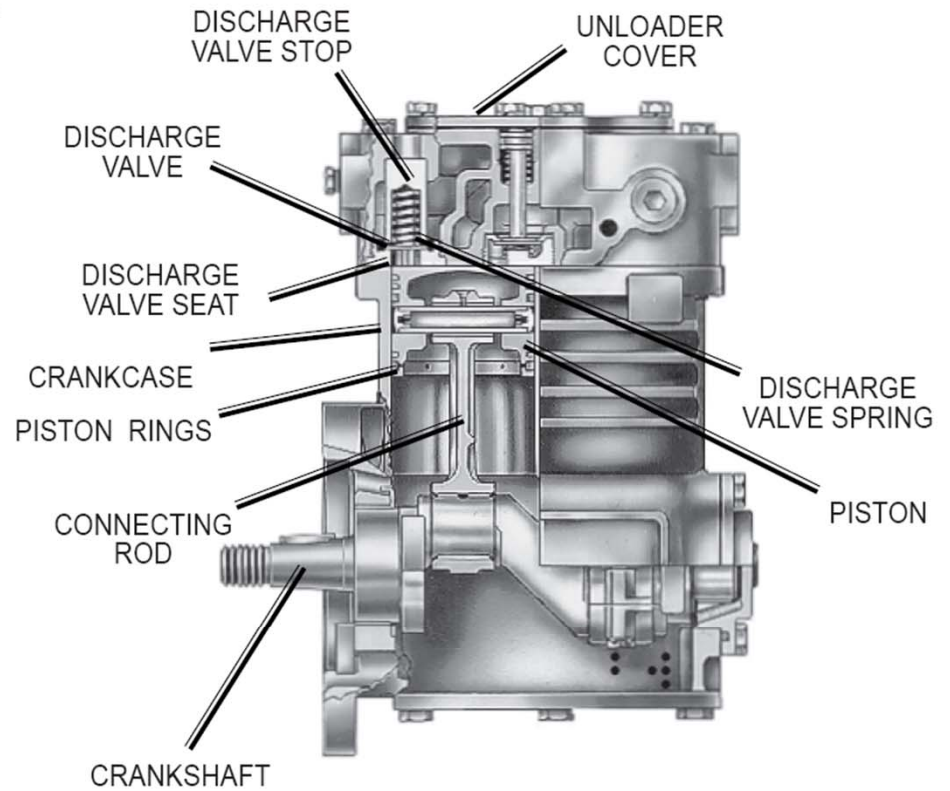

BENDIX® TU-FLO® 750 AIR COMPRESSOR
(CROSS SECTION)

BENDIX TU-FLO 550 COMPRESSOR

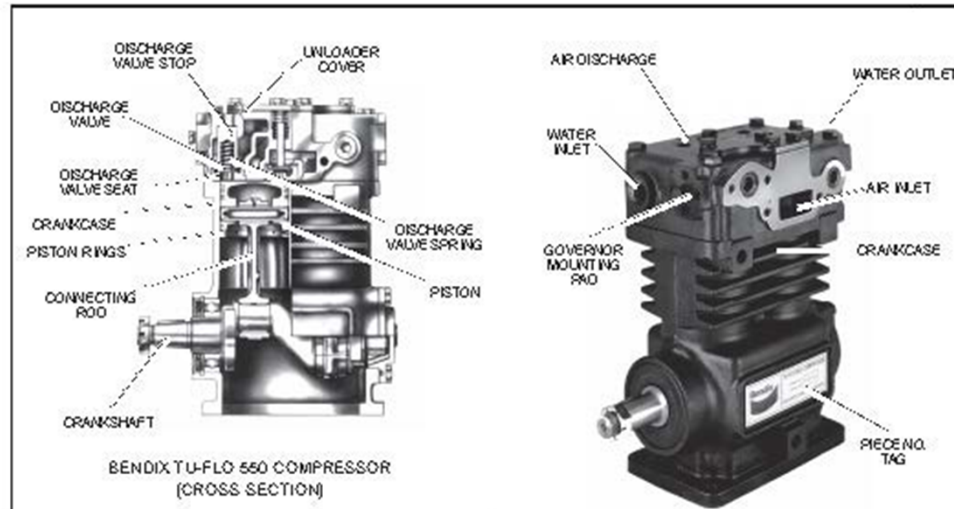

DESCRIPTION

The function of the air compressor is to provide and maintain air under pressure to operate devices in the air brake and/or auxiliary air systems. The Tu-Flo 550 compressor is a two cylinder single stage, reciprocating compressor with a rated displacement of 13.2 cubic feet per minute at 1250 RPM.

The compressor assembly consists of two major subassemblies, the cylinder head and the crankcase. The cylinder head is an iron casting which houses the inlet, discharge, and unloader valving. (See Figure 1.) The cylinder head contains the air inlet port and is designed with both top and side air discharge ports. Three water coolant ports provide a choice of coolant line connections. Governor mounting surfaces are provided at both the front and the rear of the cylinder head. The head is mounted on the crankcase and is secured by six cap screws. The Tu-Flo 550 compressor is designed such that the cylinder head can be installed in one of two positions which are 180 degrees apart. The crankcase houses the cylinder bores, pistons, crankshaft and main bearings, and provides the flange or base mounting surface.

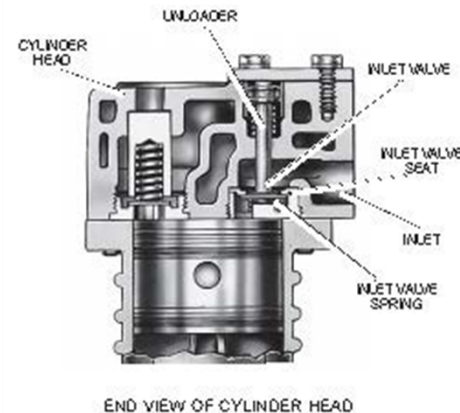

BENDIX BA-922 COMPRESSOR

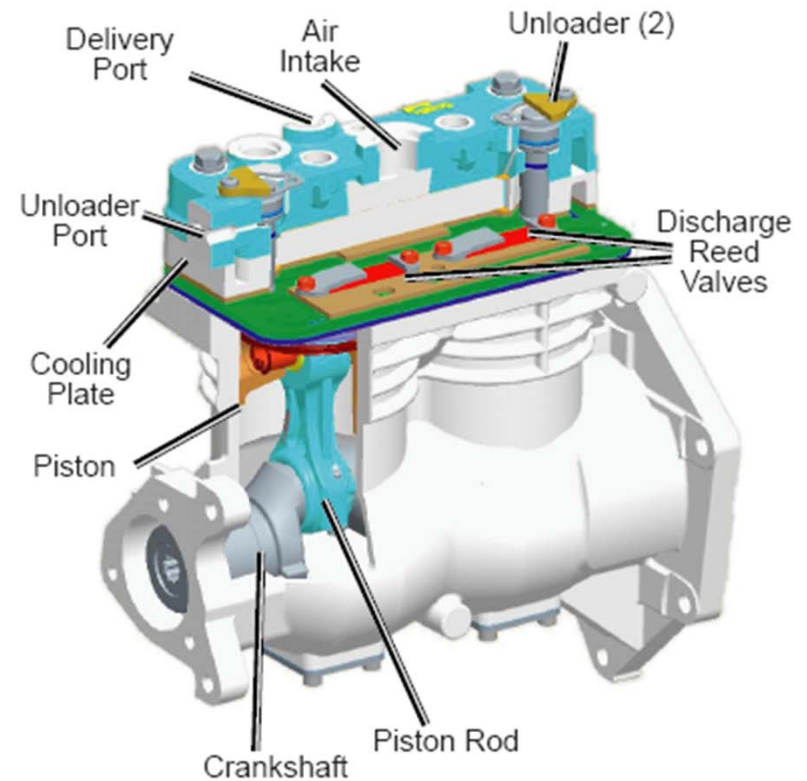
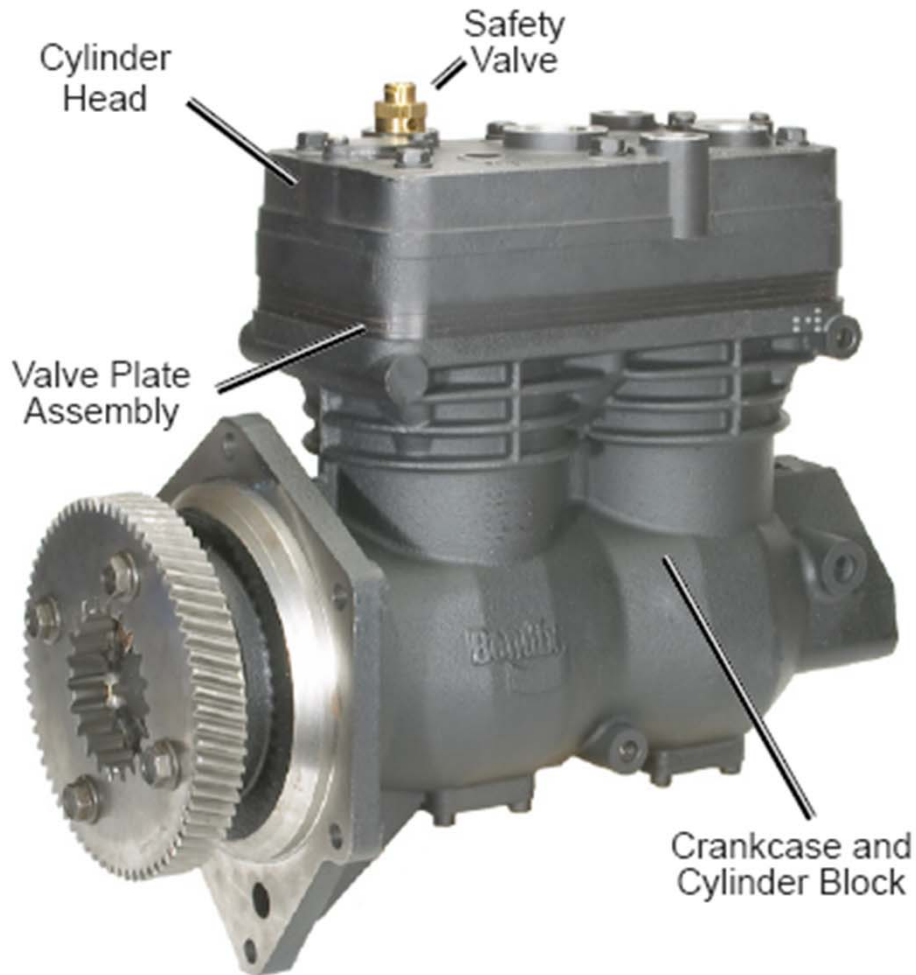

COMPRESSOR INLET

Cummins

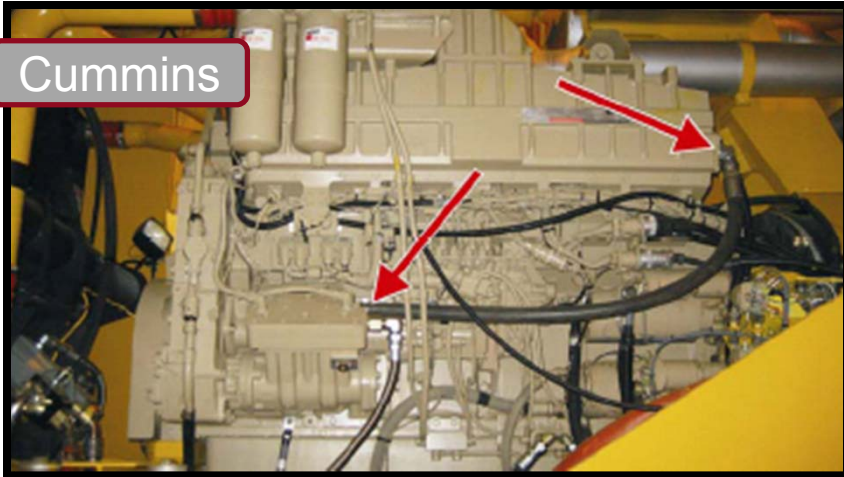

Belt driven TU-FLO 550 on L-950's & L-1150's

Engine Mounted TU-FLO 750 on L-950's & L-1150's

Detroit

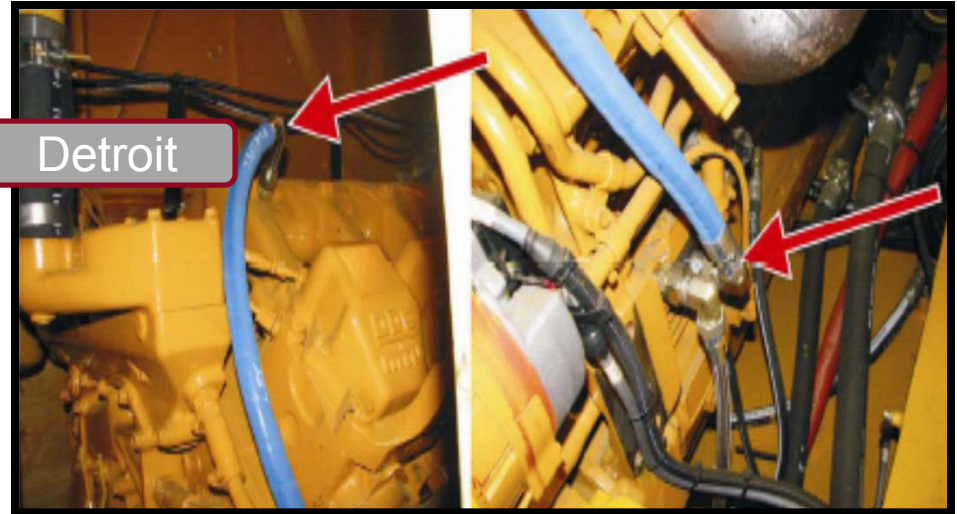

Bendix 922L-1350, L-1850, & L-2350

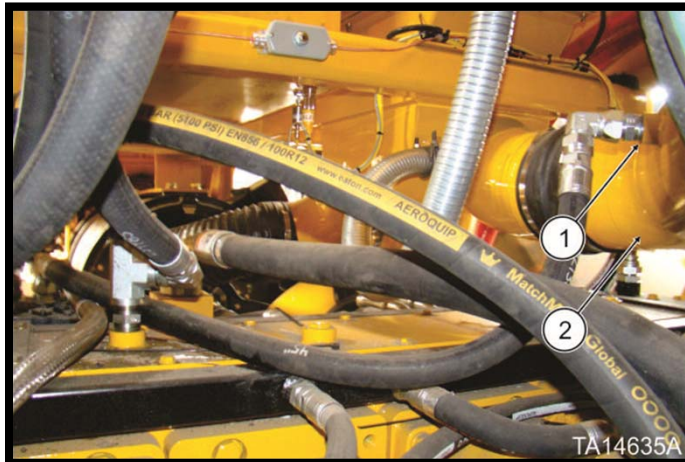

922 COMPRESSOR COOLING LUBE CIRCUIT

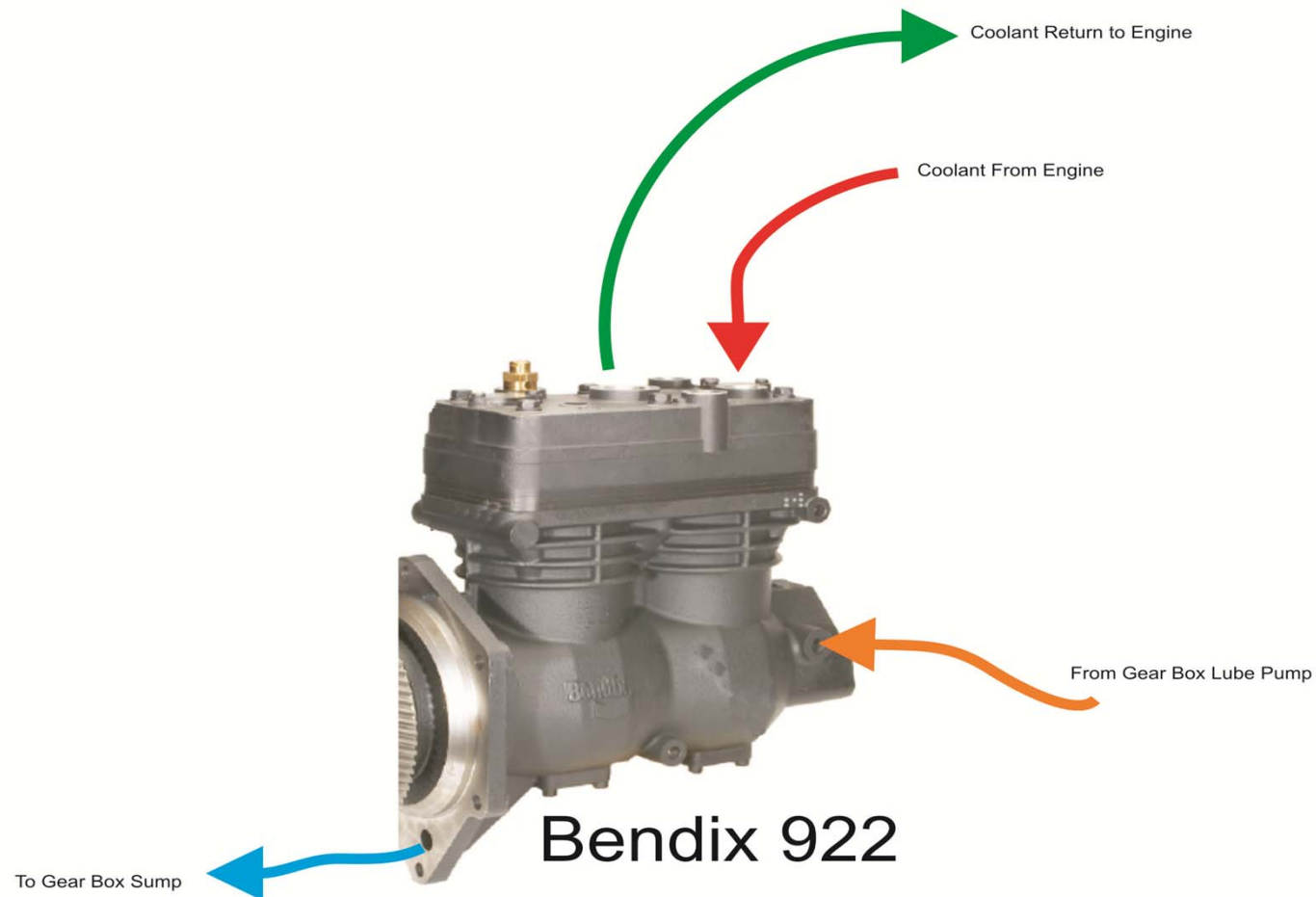

COMPRESSOR PORTING DESCRIPTION

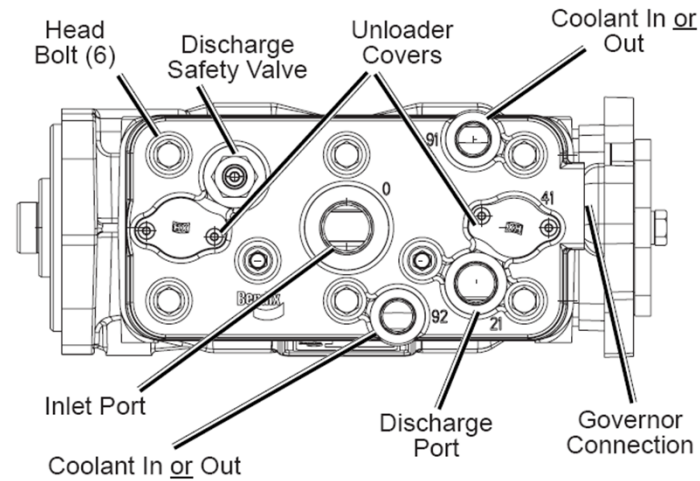

BA-922

TU-Flo
750 & 550

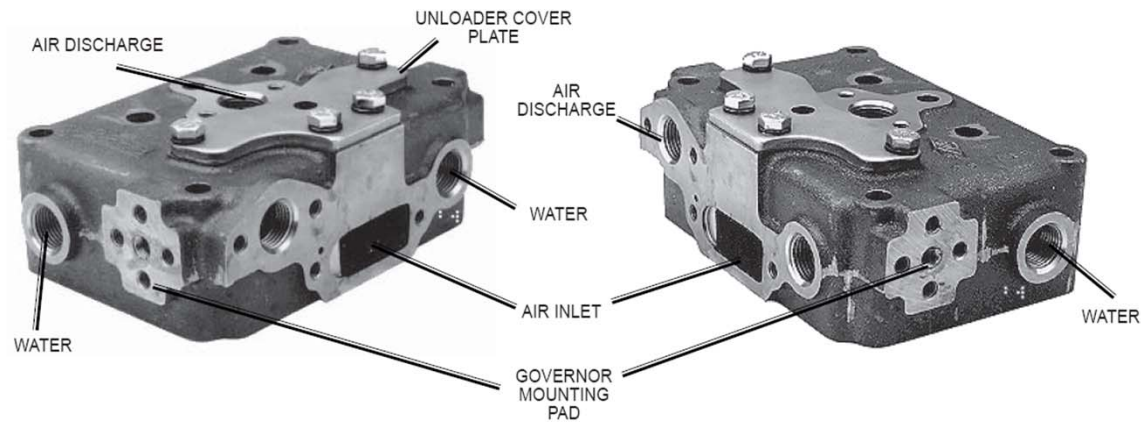

COMPRESSOR 250 PSI SAFETY RELIEF



*LeTourneau part number for safety relief
(R4244795)*

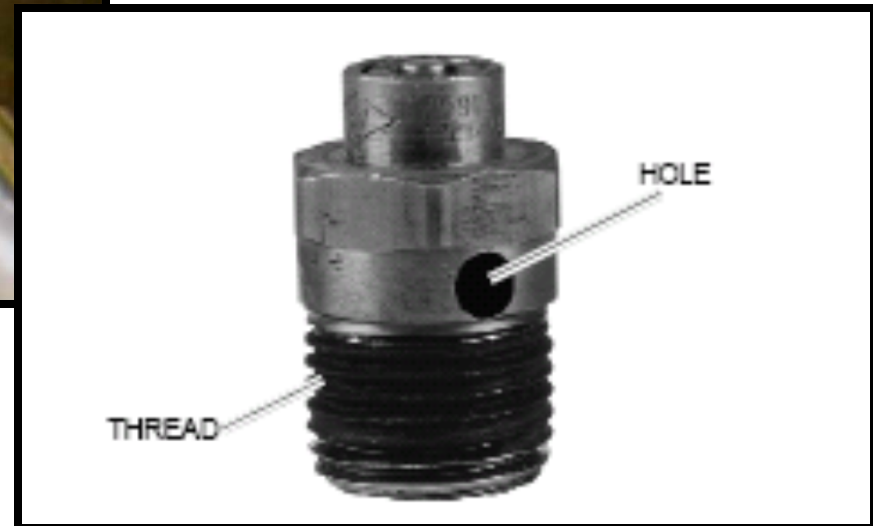

COMPRESSOR 250 PSI SAFETY RELIEF



- ❑ This hose reduces air temperature
- ❑ Does not kink
- ❑ Better heat dissipation than standard Teflon™ hoses

- ❑ Outlet Temperature is about 375 degrees
- ❑ This hose brings it down to about 175 degrees



AD-IP BENDIX AIR DRYER

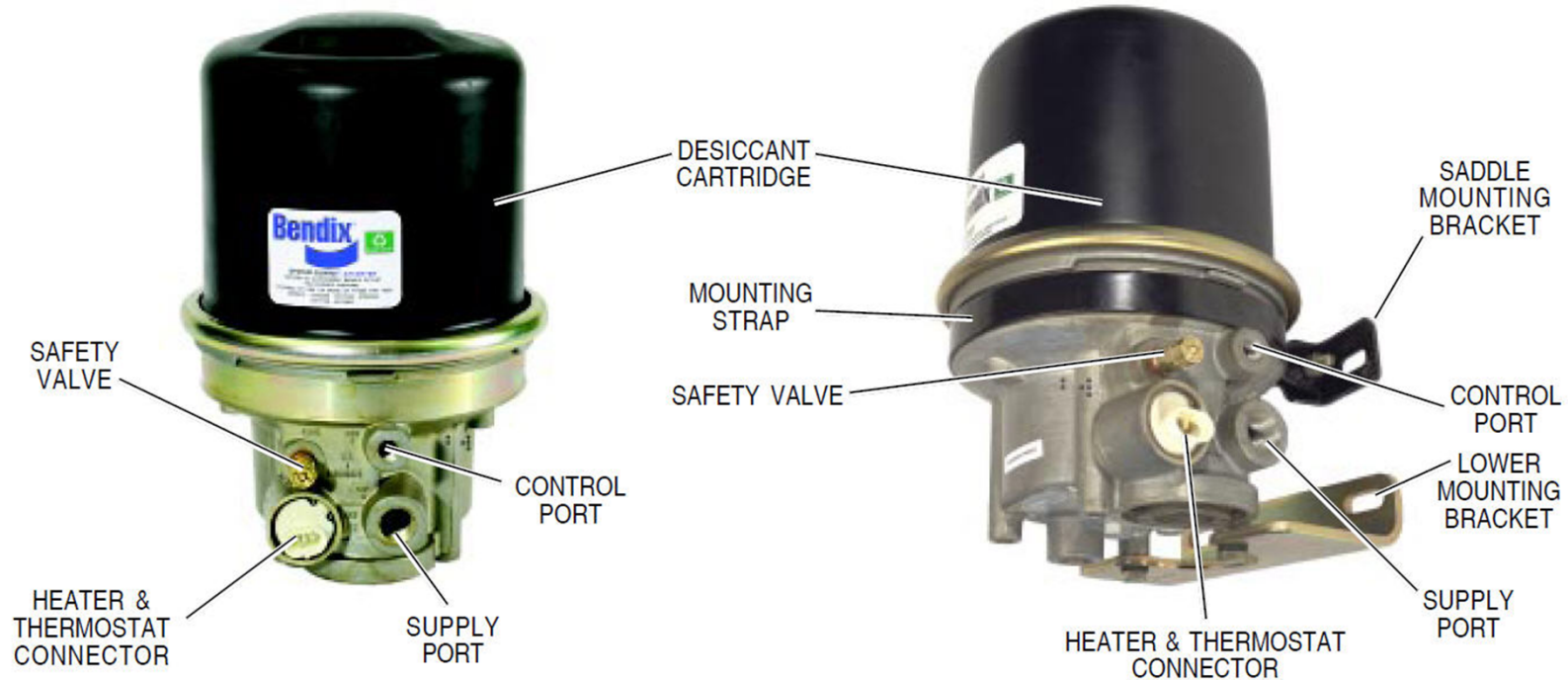

- ❑ 200 PSI Safety Relief
- ❑ 24 VDC Heater and Thermostat
- ❑ Desiccant Cartridge
- ❑ DLU Purge Valve
- ❑ Outlet Check Valve

AIR DRYER DLU [DISCHARGE LINE UNLOADER]

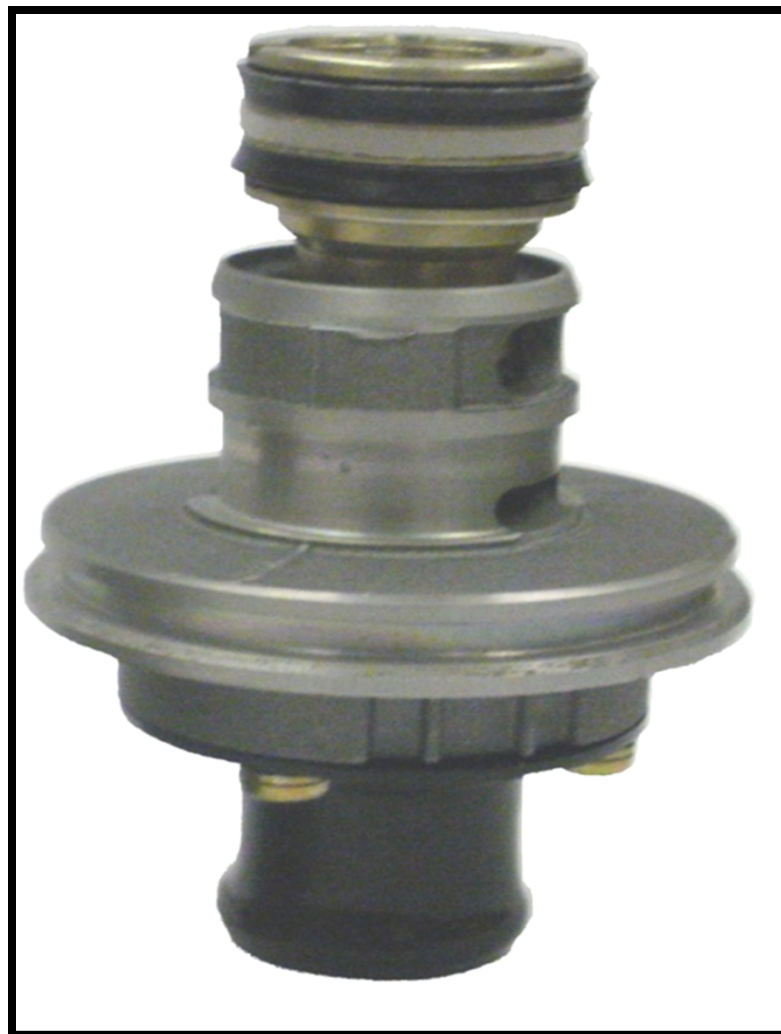

DRYER OPERATION CYCLE – SYSTEM CHARGING

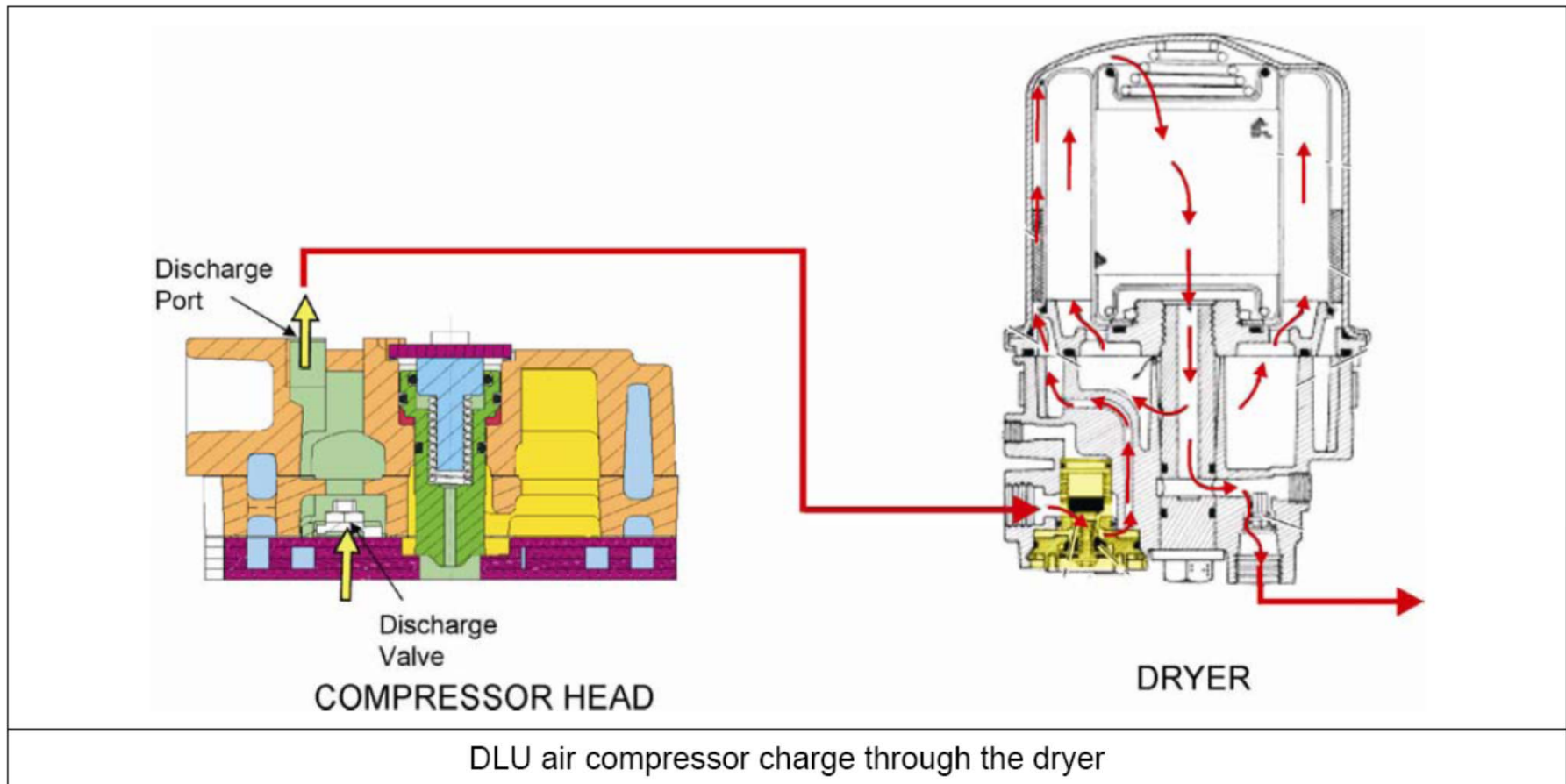

DRYER OPERATION CYCLE – SYSTEM UNLOADING AND PURGE

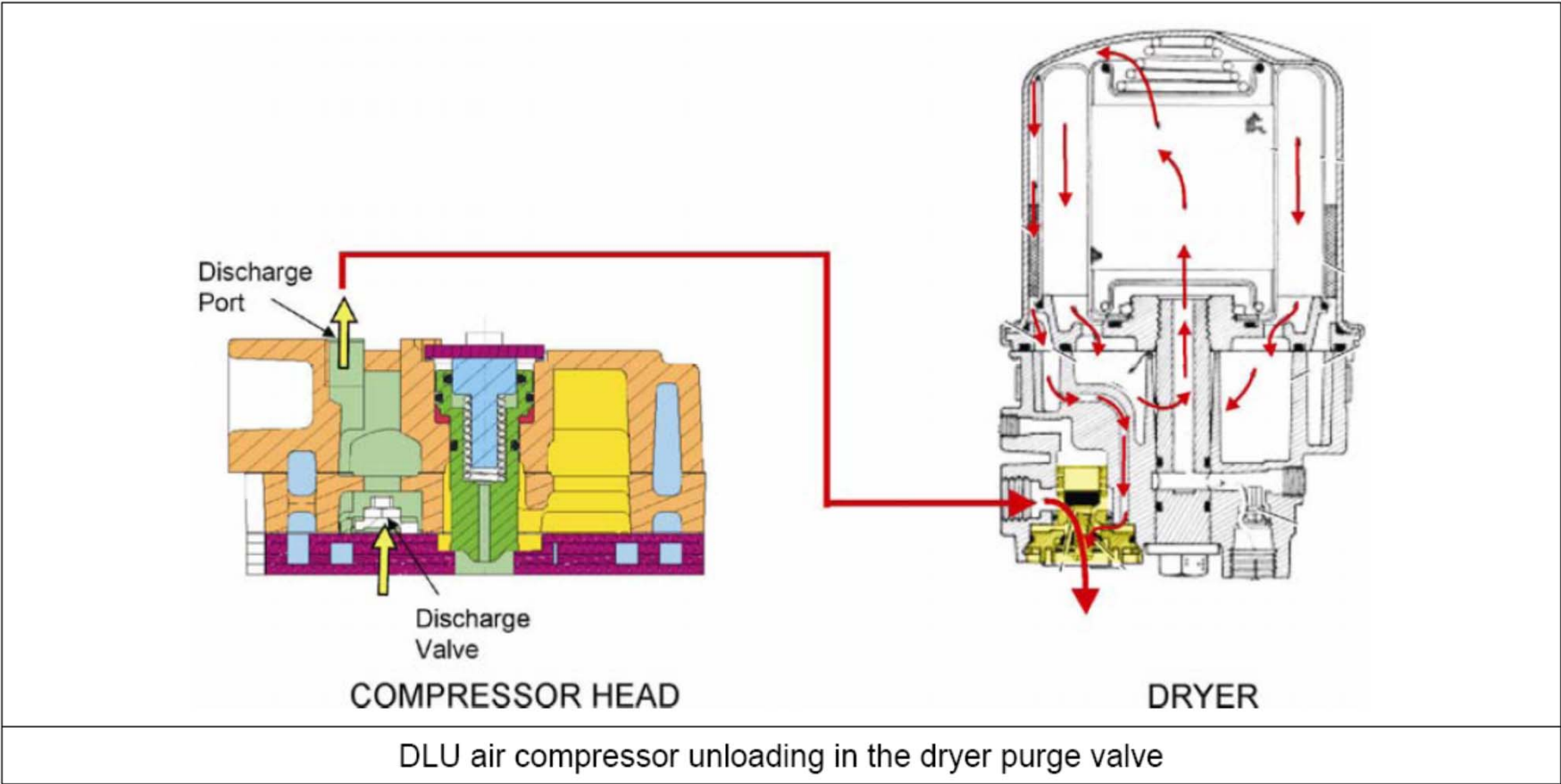

GOVERNOR DESCRIPTION

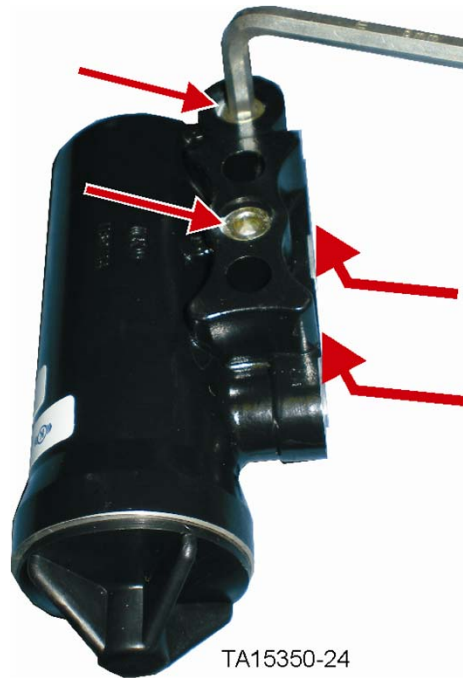

TA15350-24

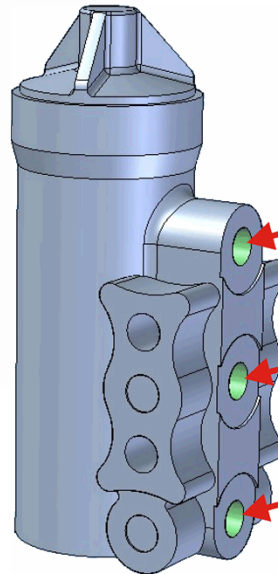

Exhaust Check Valve

Unloader port - to DLU valve on updated system
(or head of compressor on old system)

Reservoir port - from distribution tank

TA15350-15

DISTRIBUTION TANKS - GENERAL LOCATION



Locations of tanks vary from loader model

DISTRIBUTION TANKS VALVES

Check Valve

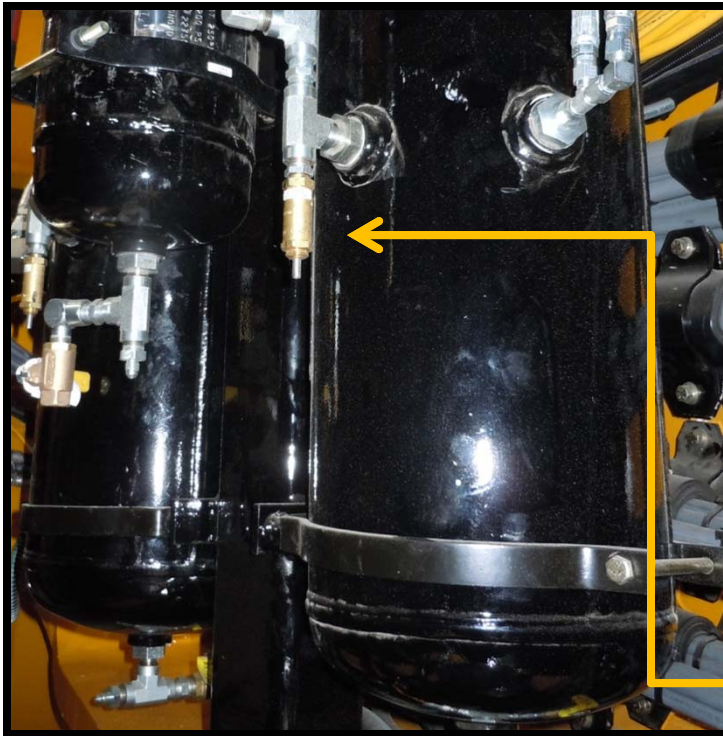

175 psi Safety Valve

RESERVOIR DRAIN VALVES

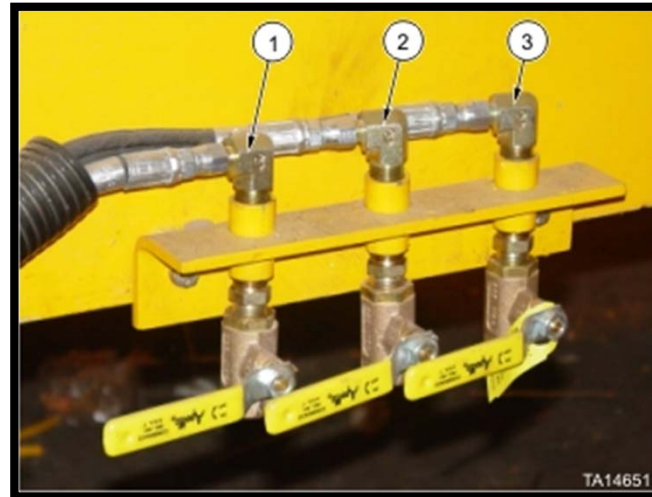
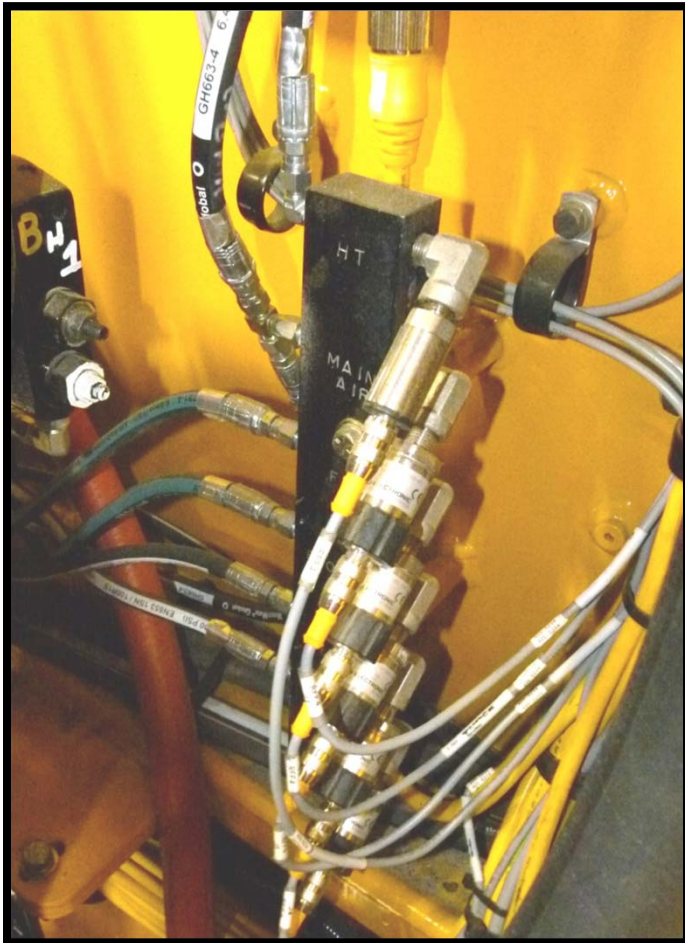

- 1) Distribution
- 2) Klenz
- 3) Rear Brake

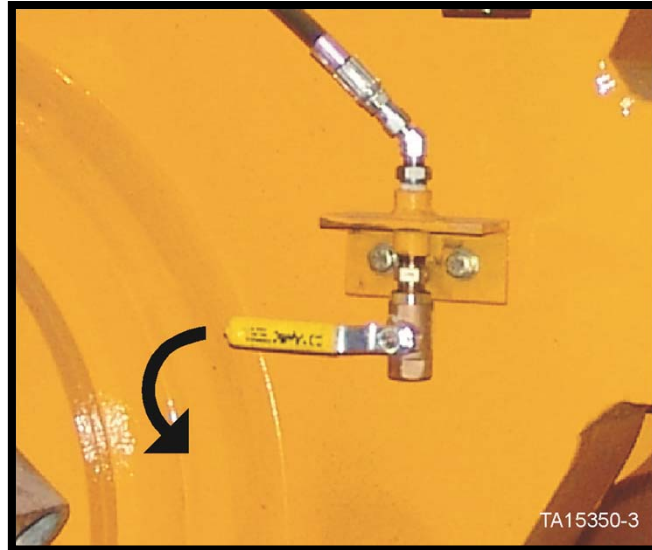

AUXILIARY FUNCTIONS - DUMP VALVE SOLENOID TD

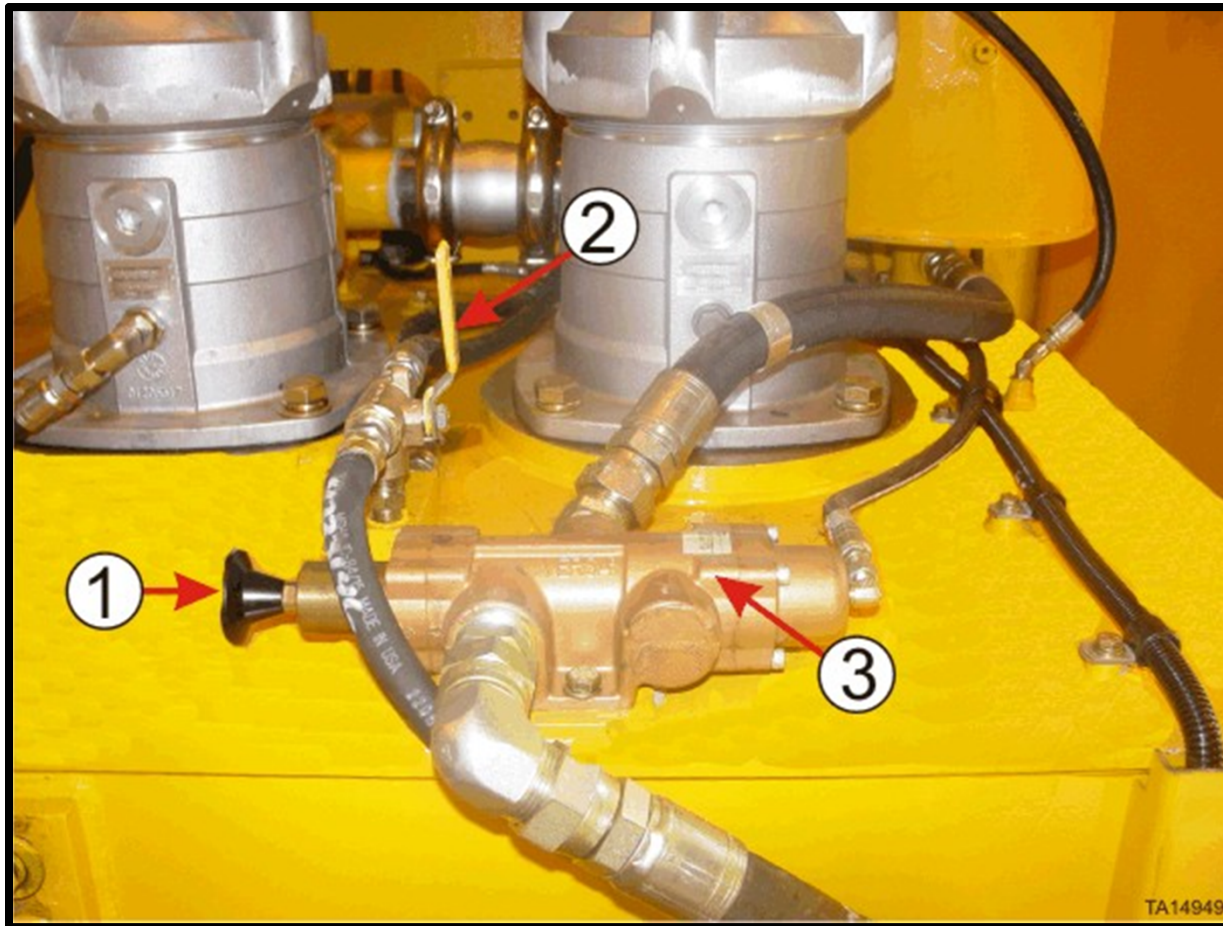

1. Shuttle Valve Actuator
2. Manual Valve
3. Valve Body

AIR SYSTEM BRAKE COMPONENTS

- Brake Pedal
- Park Brake Solenoid (Front Solenoid PB1 Rear Solenoid PB2)
- Brake Relay Valve
- Brake Actuator
- Pressure Transducer

BRAKE PEDAL

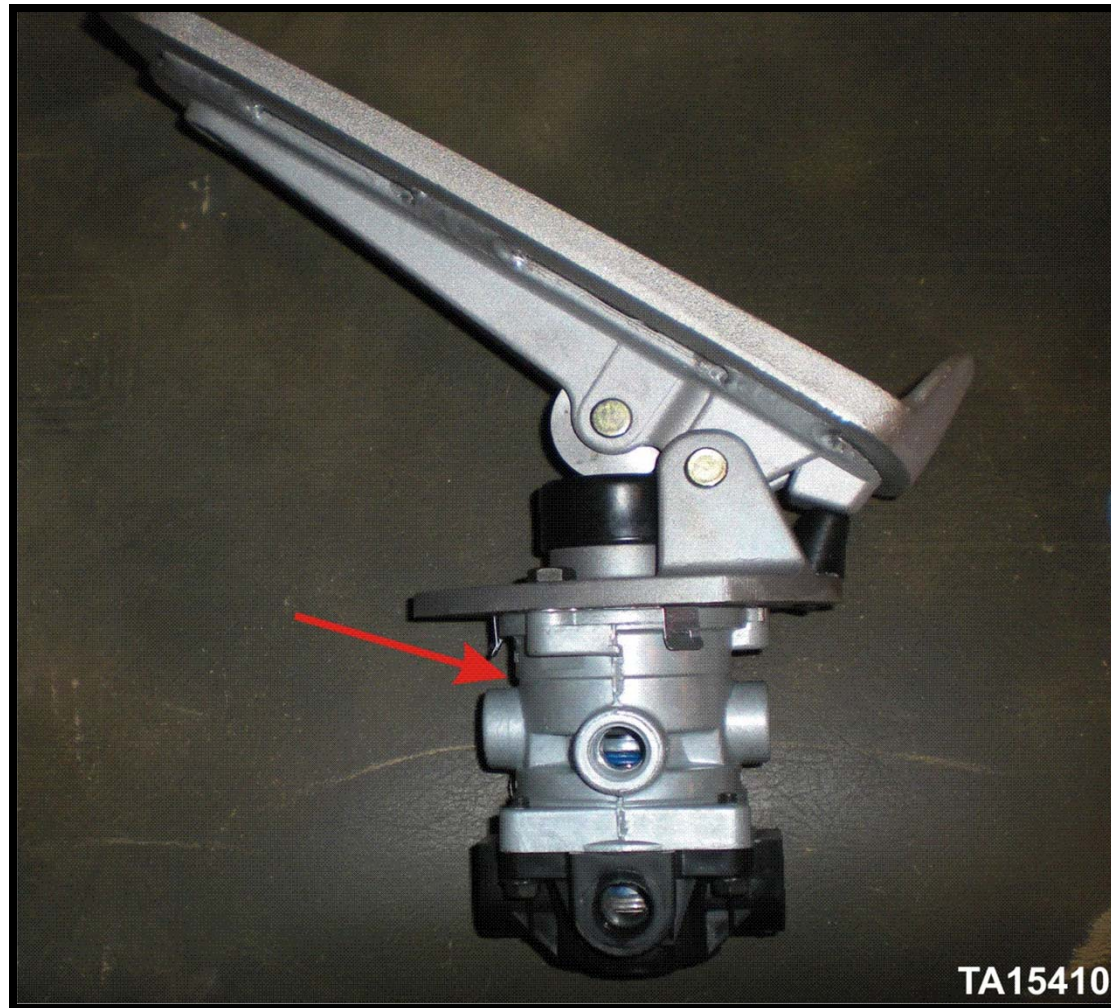

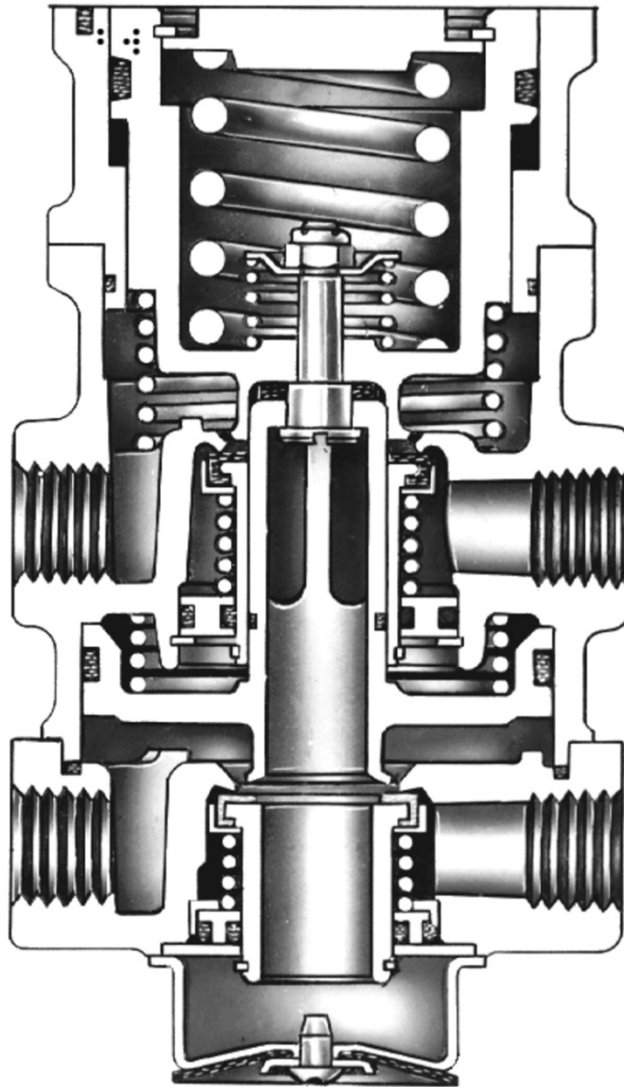

TREADLE VALVE CUTAWAY



TREADLE VALVE

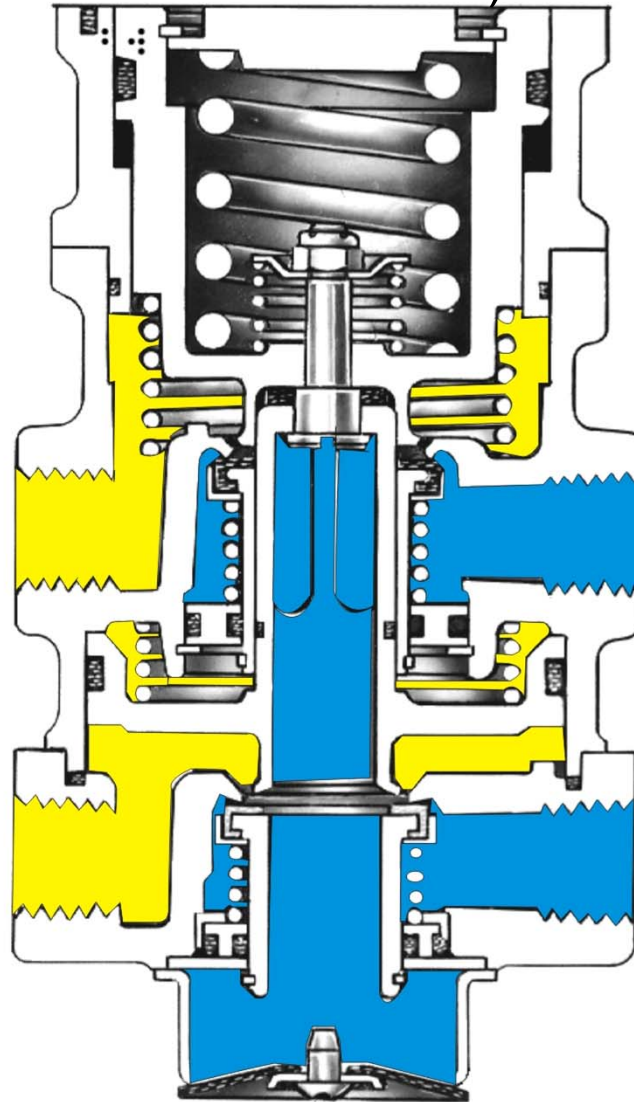

(NORMAL STATE – BRAKES NOT APPLIED)

-  Air Pressure
-  Air going down to brake actuator



TREADLE VALVE

(BRAKES APPLIED)

-  Air Pressure
-  Air going down to brake actuator

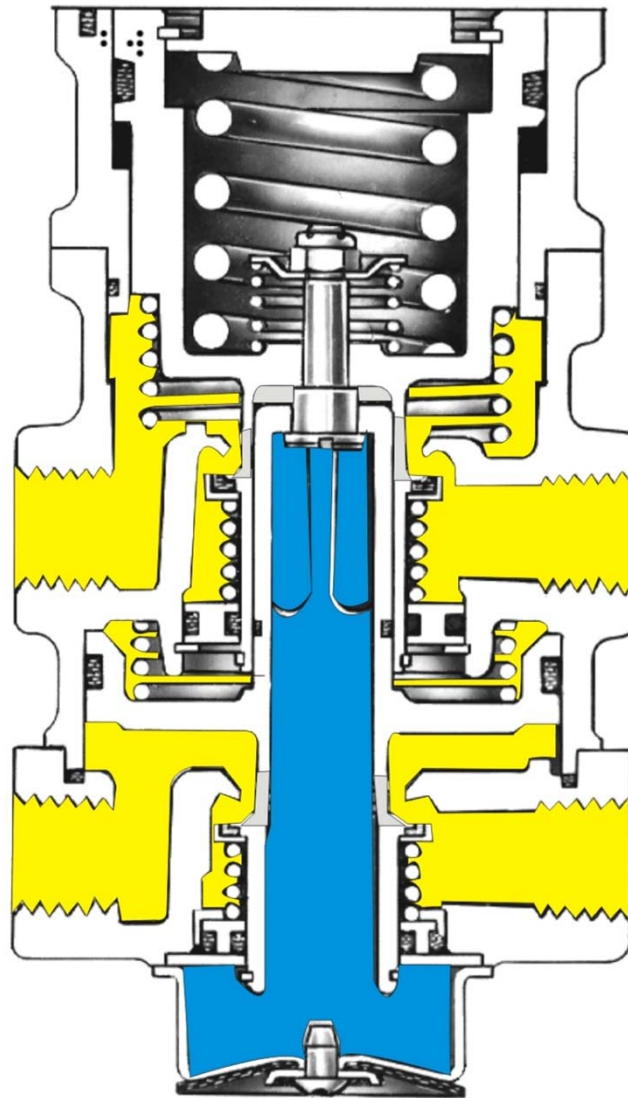

- Step on brakes
- Spring shifts down
- Pressurized air moves from left to right

BRAKE RELAY VALVES

- 1) Service Brake
- 2) Park Brake

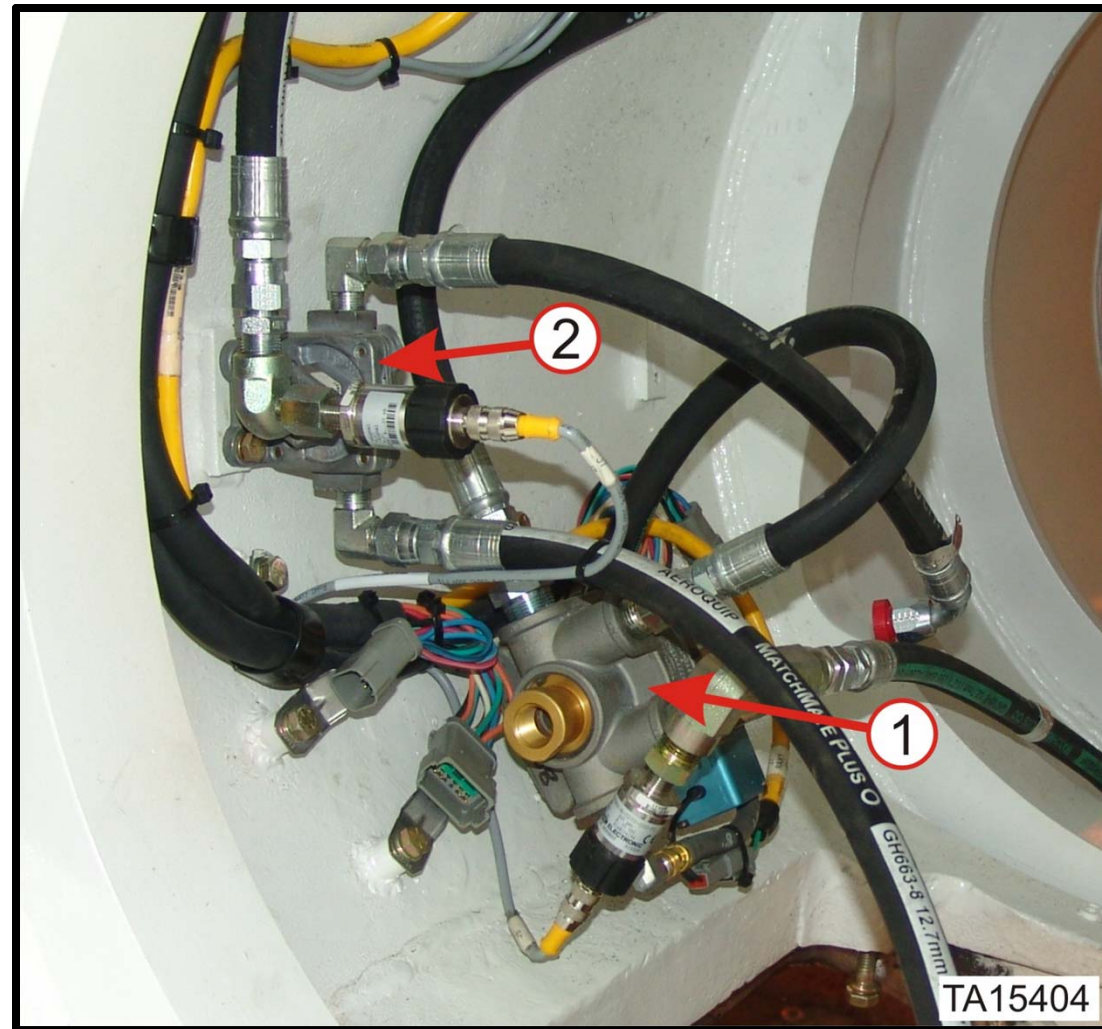

BRAKE RELAY VALVE - NOT ACTUATED

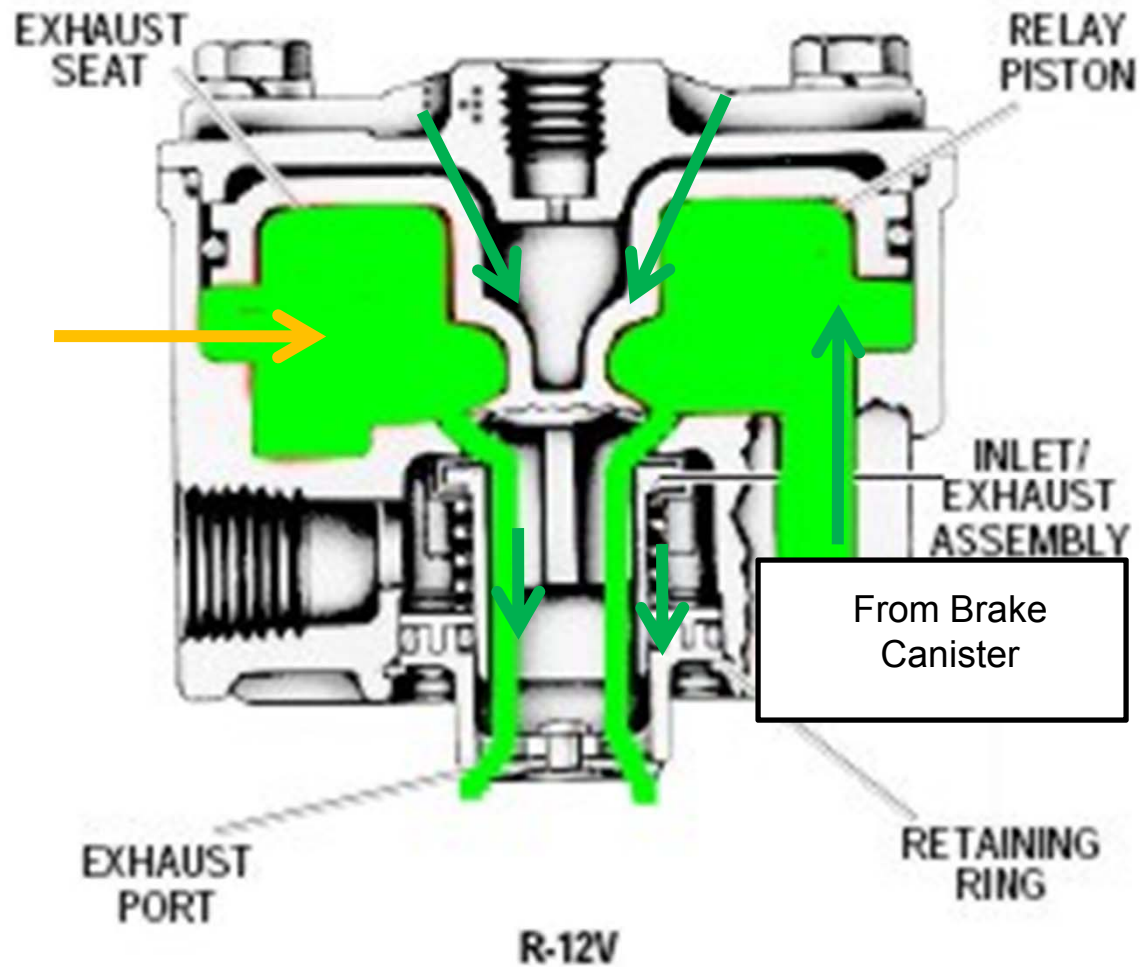

BRAKE RELAY VALVE - ACTUATED

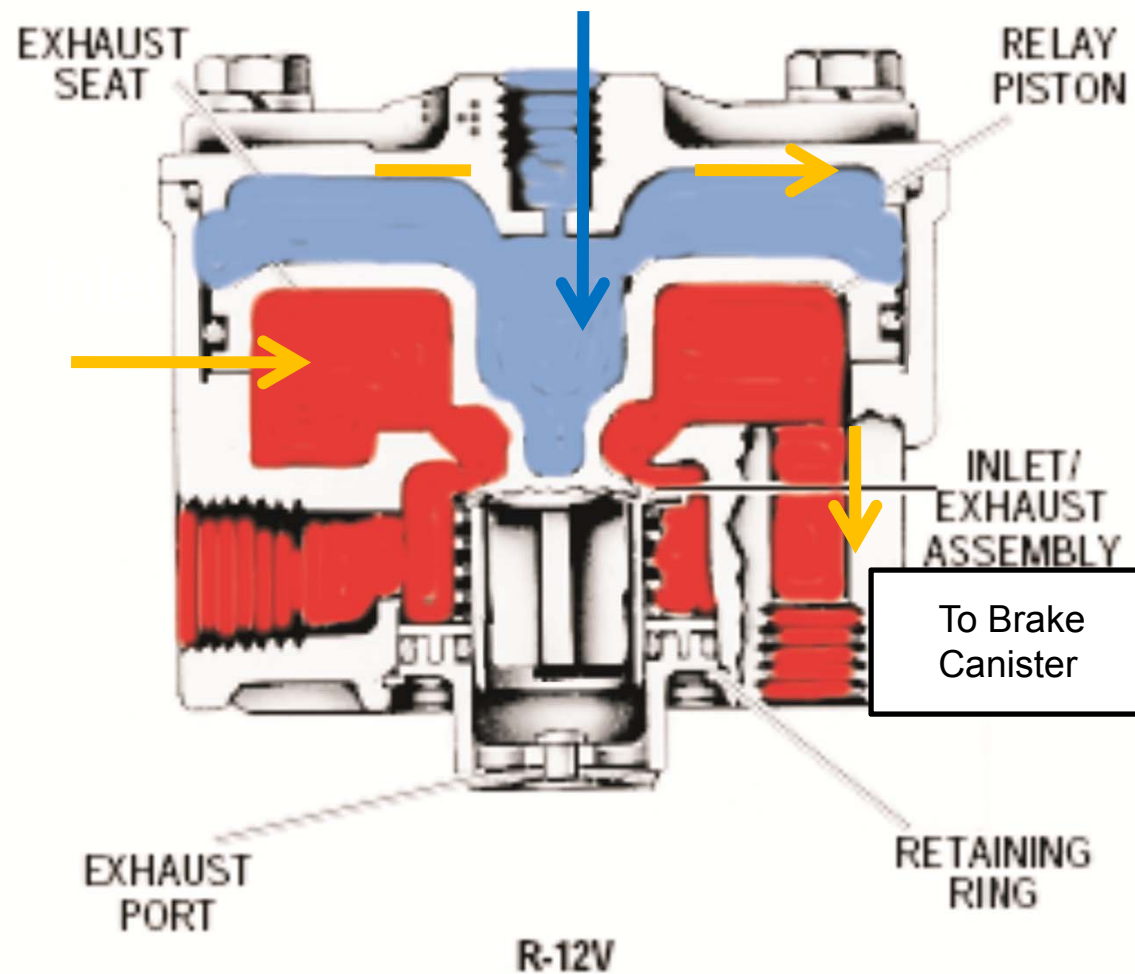

L-950 QUICK REACTION VALVE

QRV™ Quick Release Valve

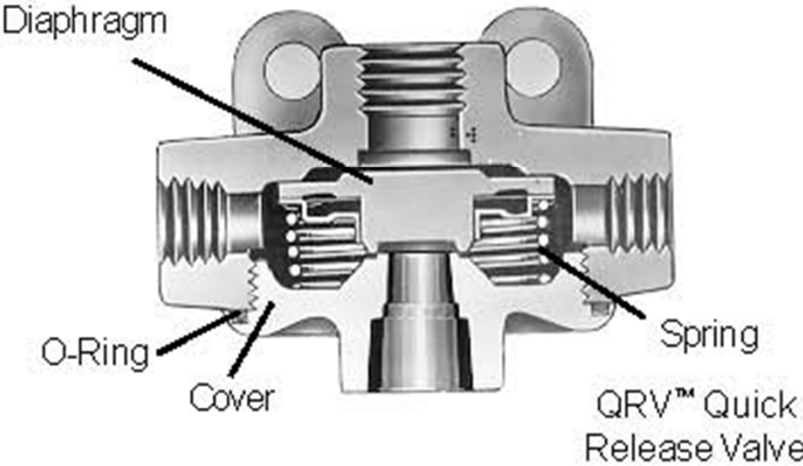
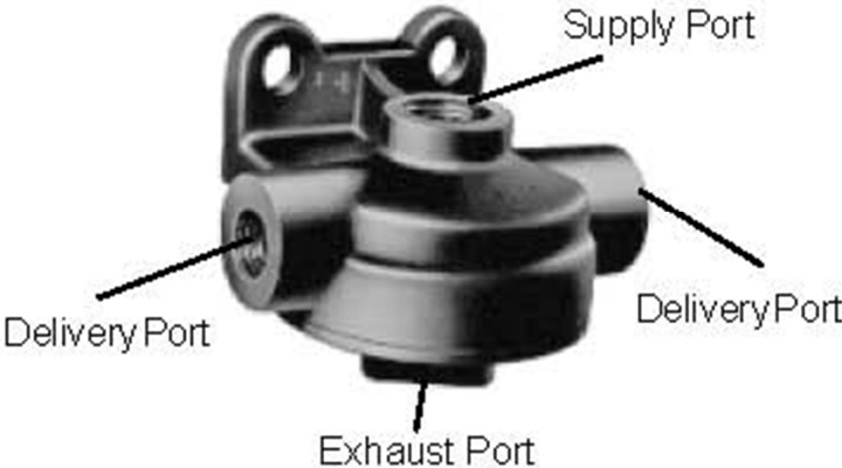

L-950 QUICK REACTION VALVE

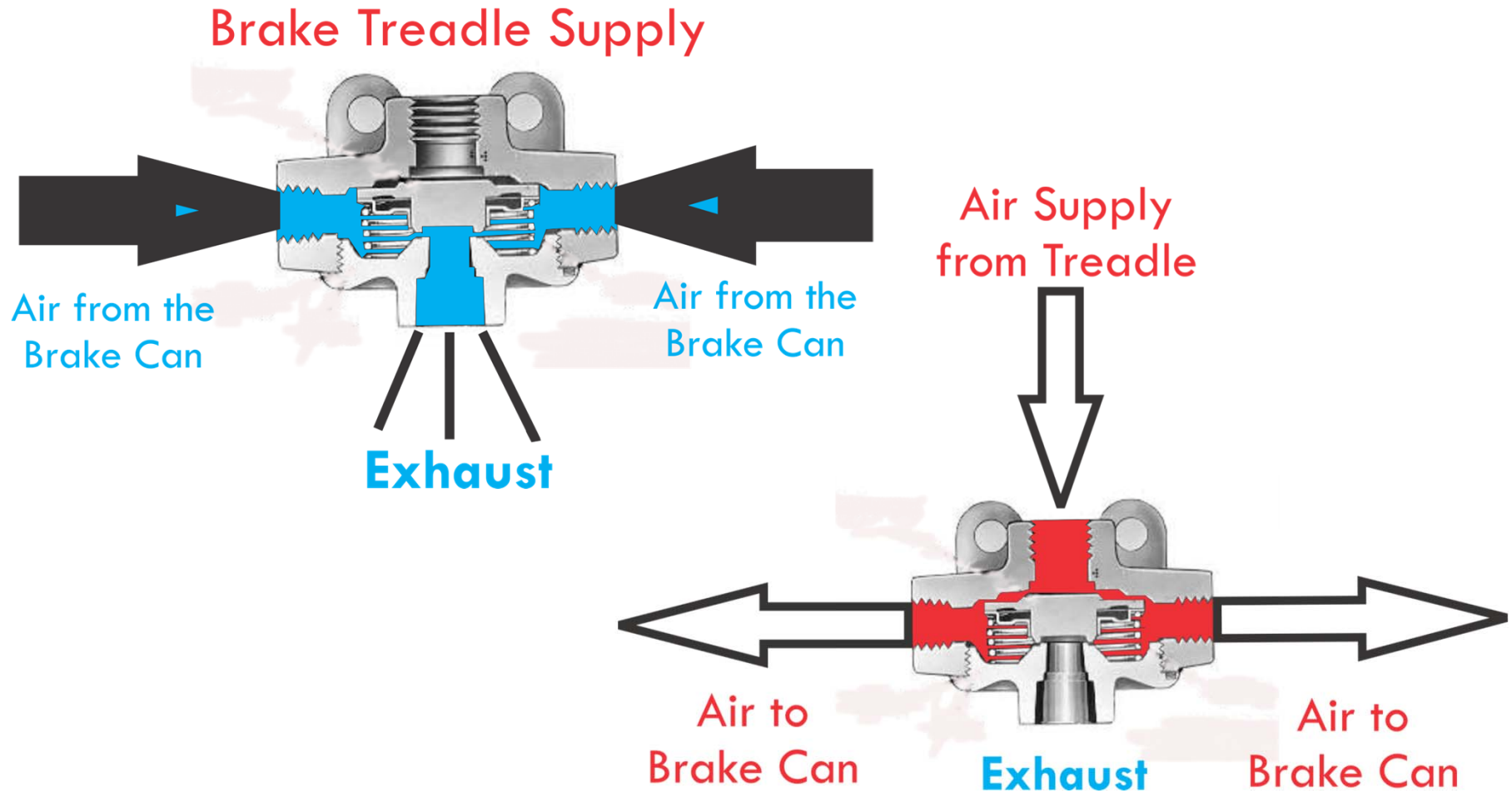

BRAKE ACTUATOR

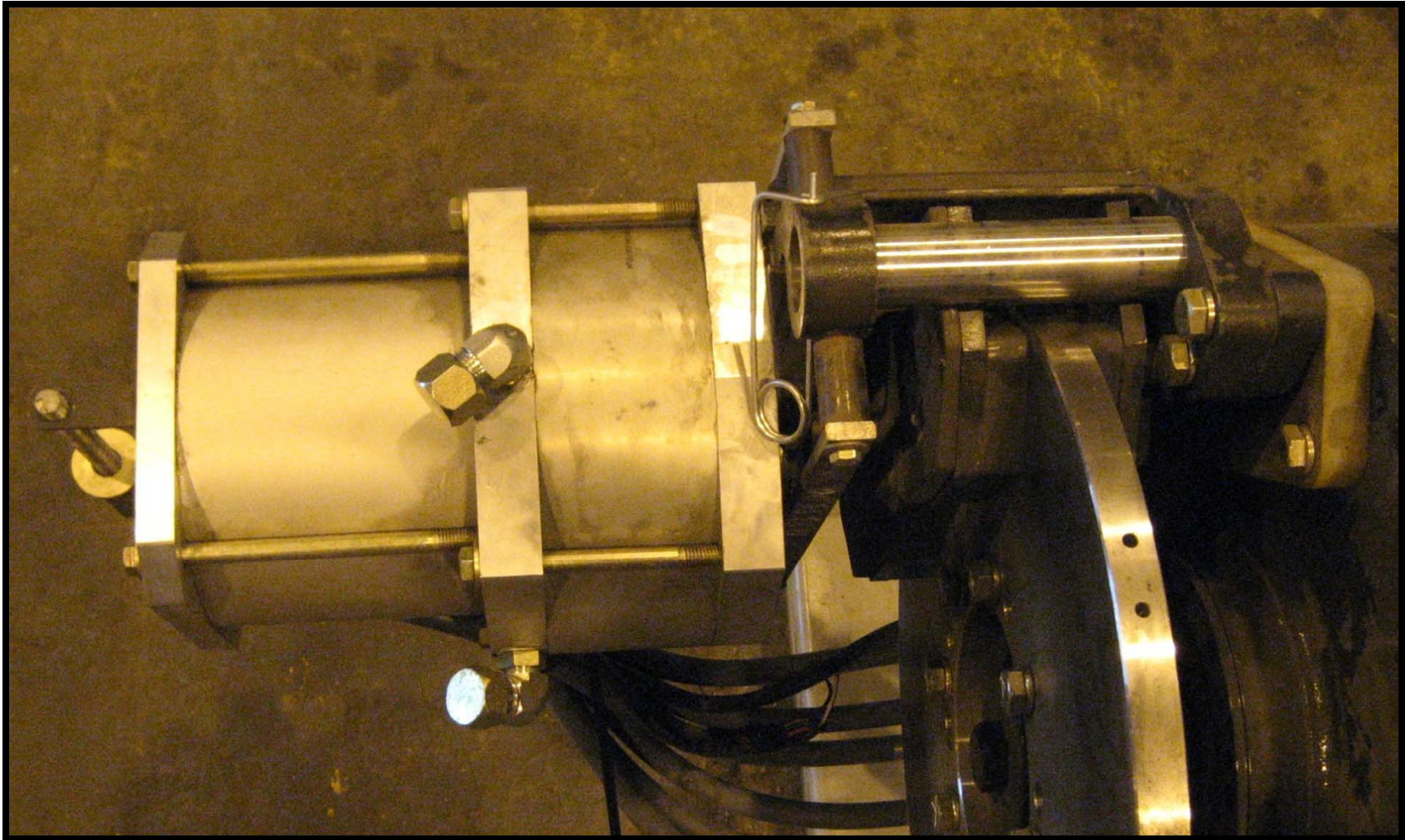

BRAKE ACTUATOR

Section A-A

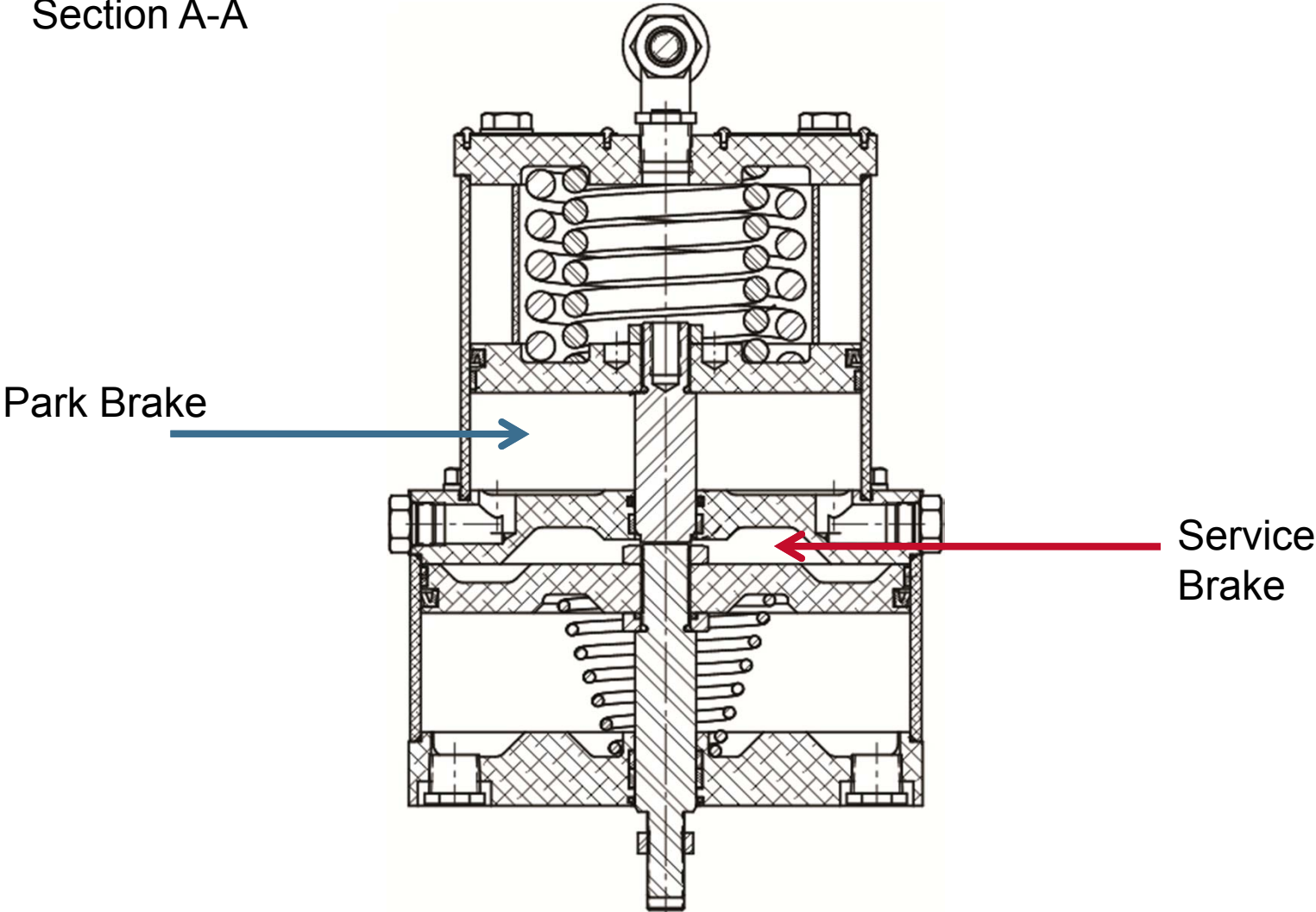

BRAKE PRESSURE TRANSDUCER

- 1) Service Brake
- 2) Park Brake

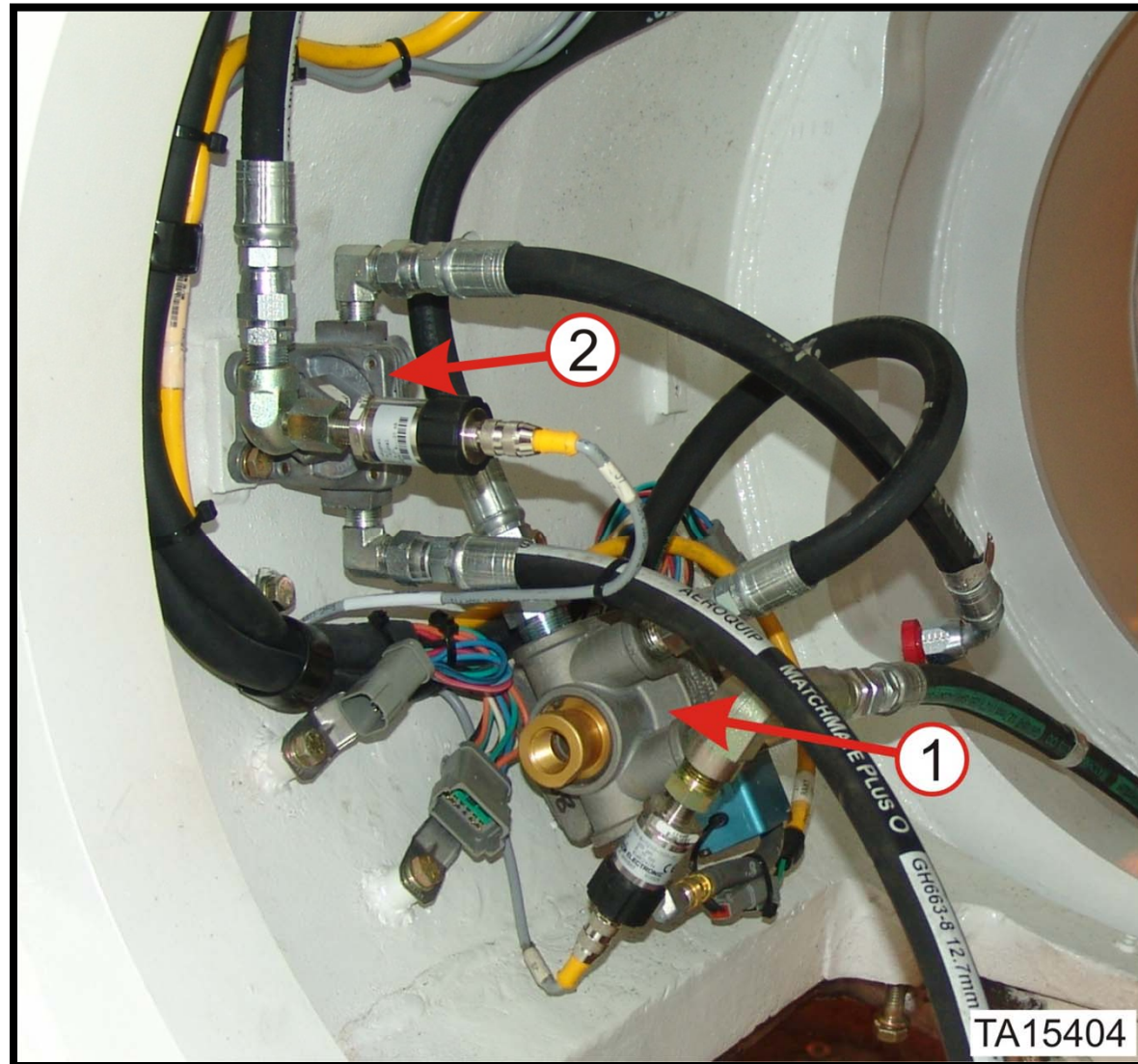

KLENZ TANK



AIR BOX

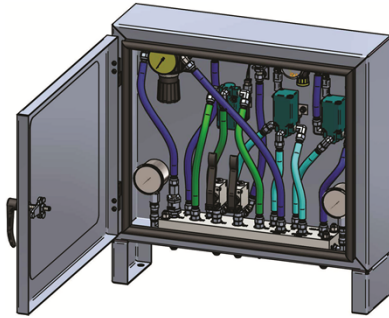

- 1) Distribution Reservoir Pressure
- 2)Klenz Supply Regulator
- 3)SOL TD
- 4)12 PSI Relief Valve
- 5)Check Valve
- 6)SOL KA
- 7)Hyd Supply Regulator
- 8)SOL HA
- 9)Klenz Reservoir Pressure
- 10)To/From Klenz Reservoir
- 11)To SOL TD
- 12)To Hyd Reservoir
- 13)To Klenz Manifold
- 14)Manual Shut Off
- 15)From Distribution Reservoir
- 16)Check Valve

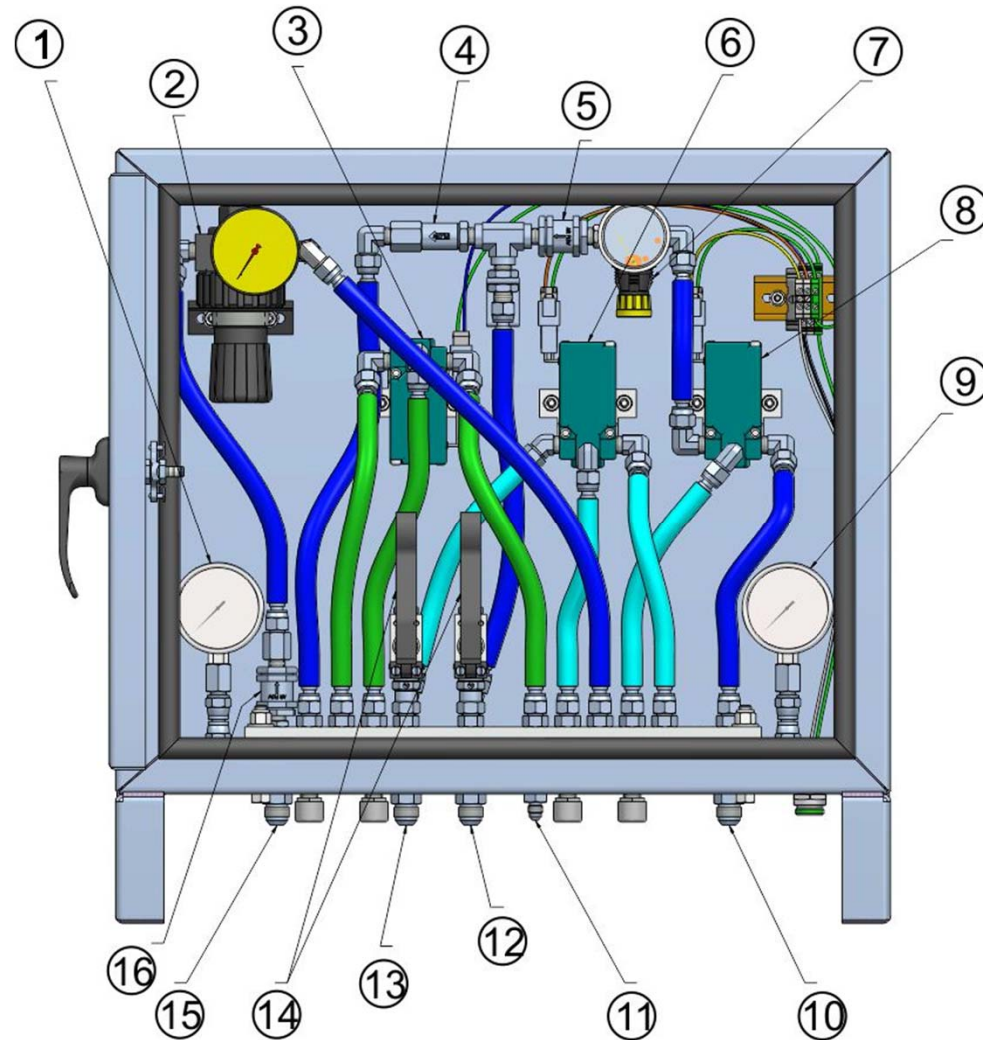

AIR BOX MANIFOLD

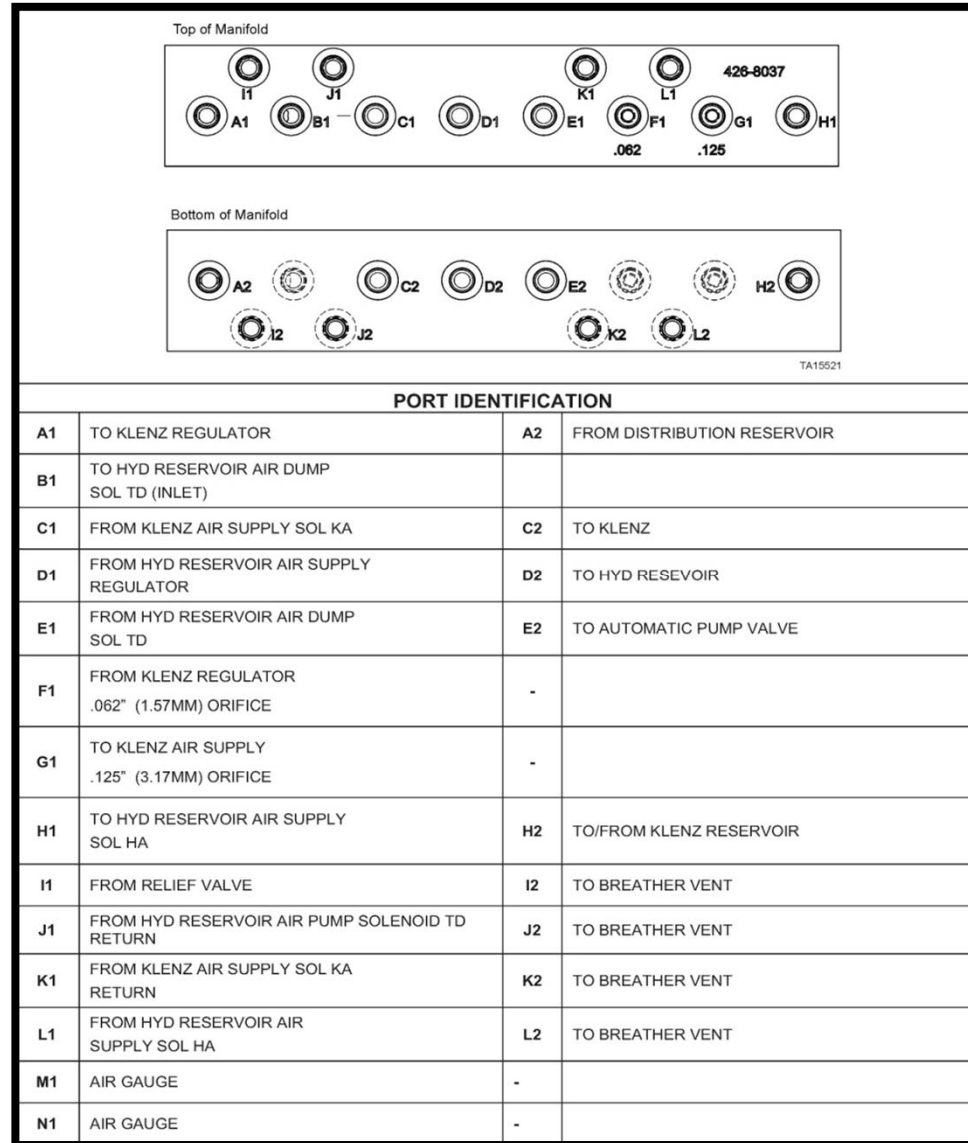

AIR SYSTEM - HYDRAULIC TANK AIR

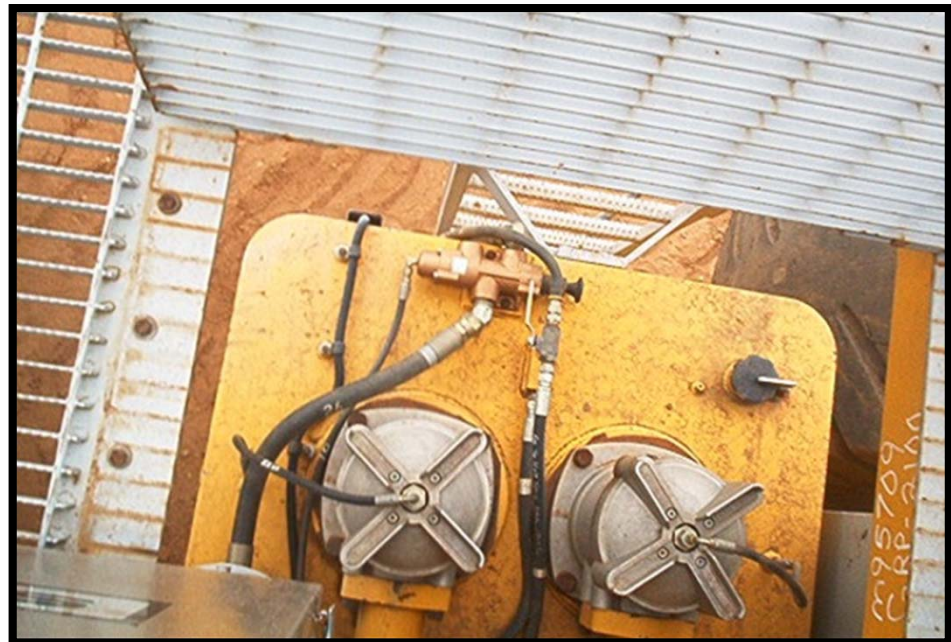

AIR SYSTEM - HYDRAULIC TANK DUMP VALVES

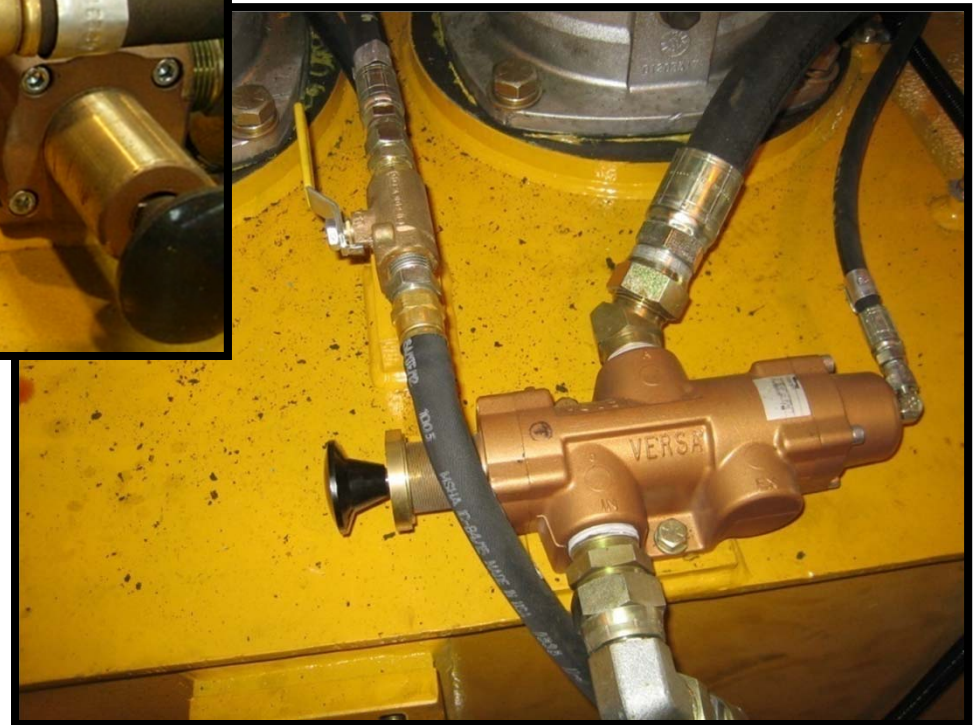

AIR SYSTEM HYDRAULIC SURGE TANK

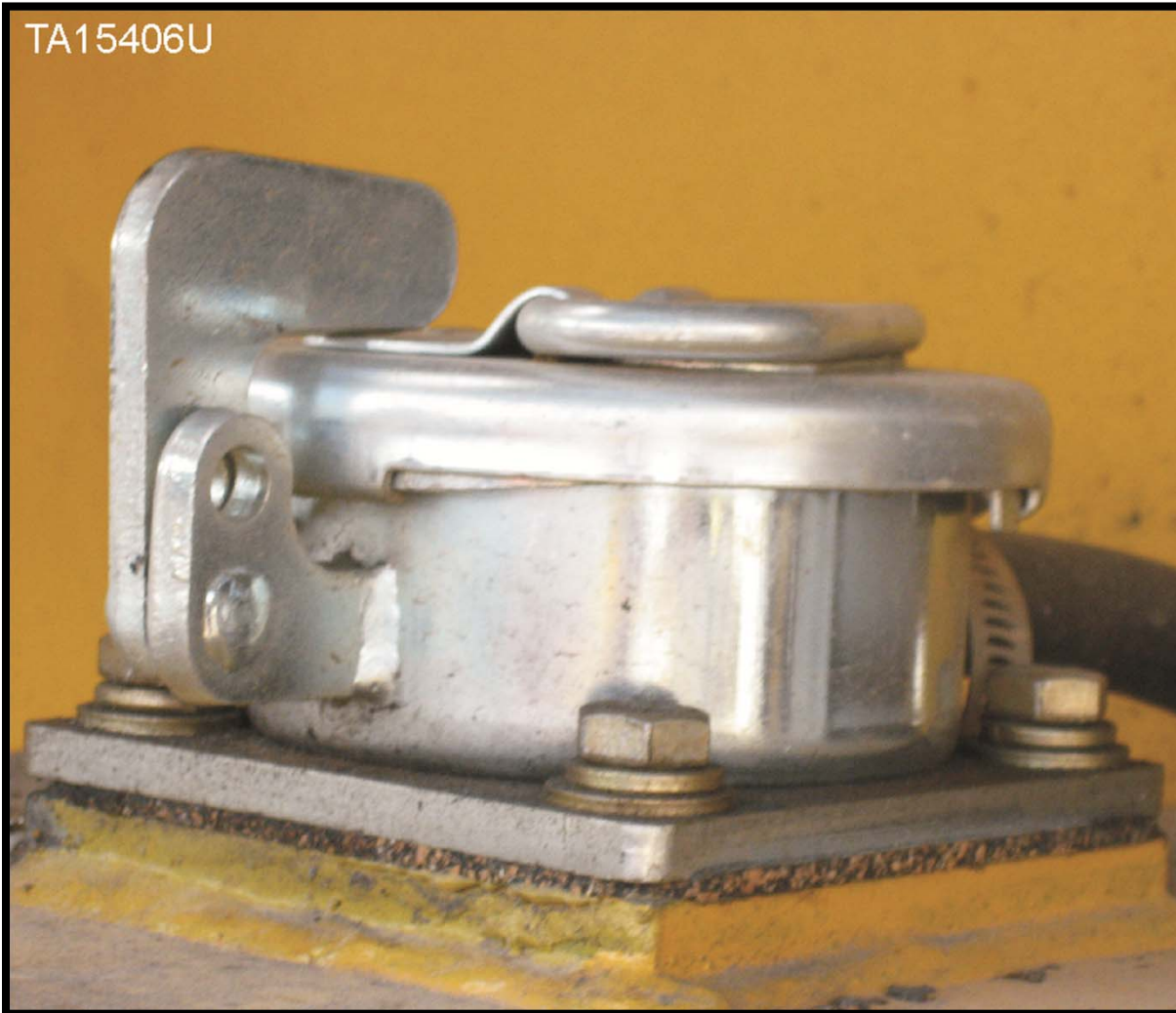

AIR SYSTEM HYDRAULIC TANK TRANSDUCER

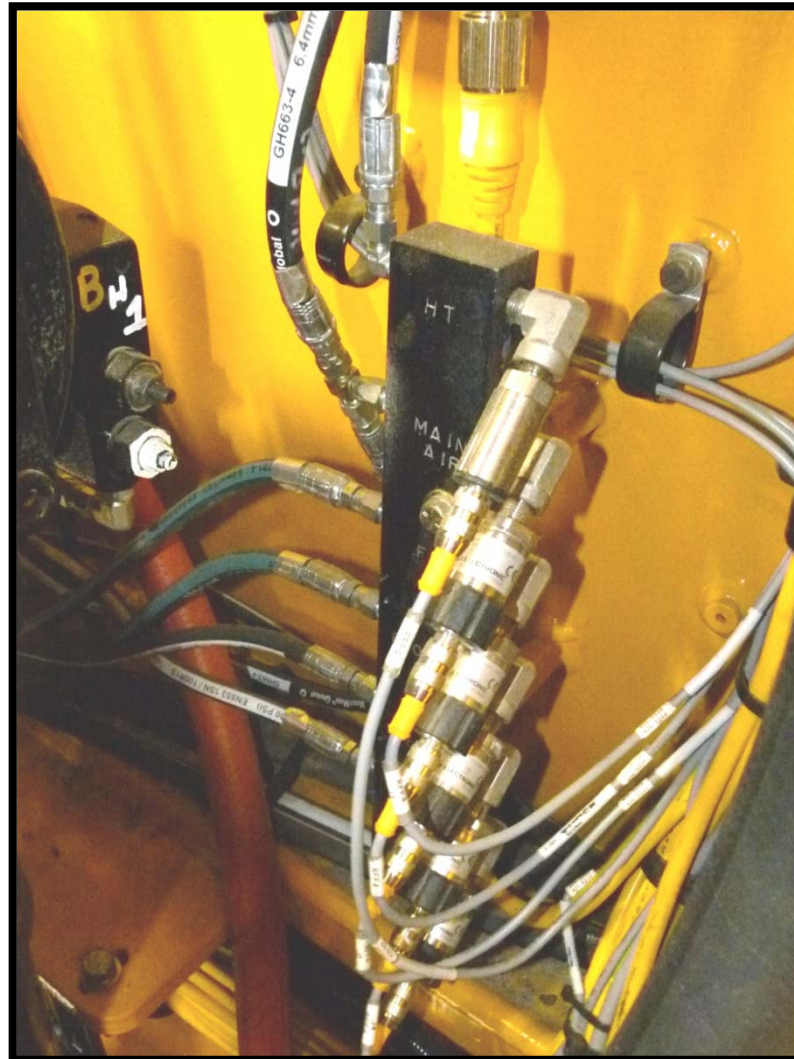

AIR SYSTEM KLENZ

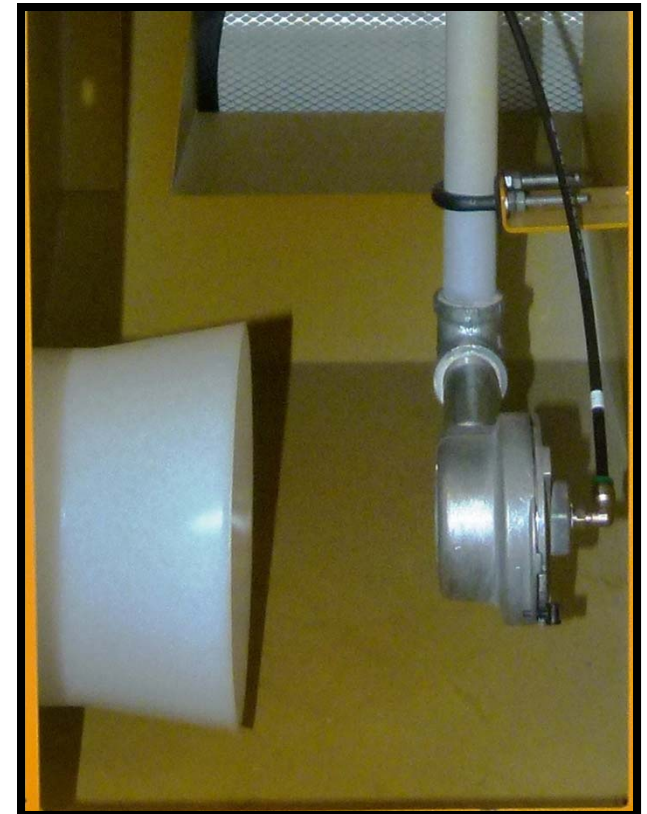
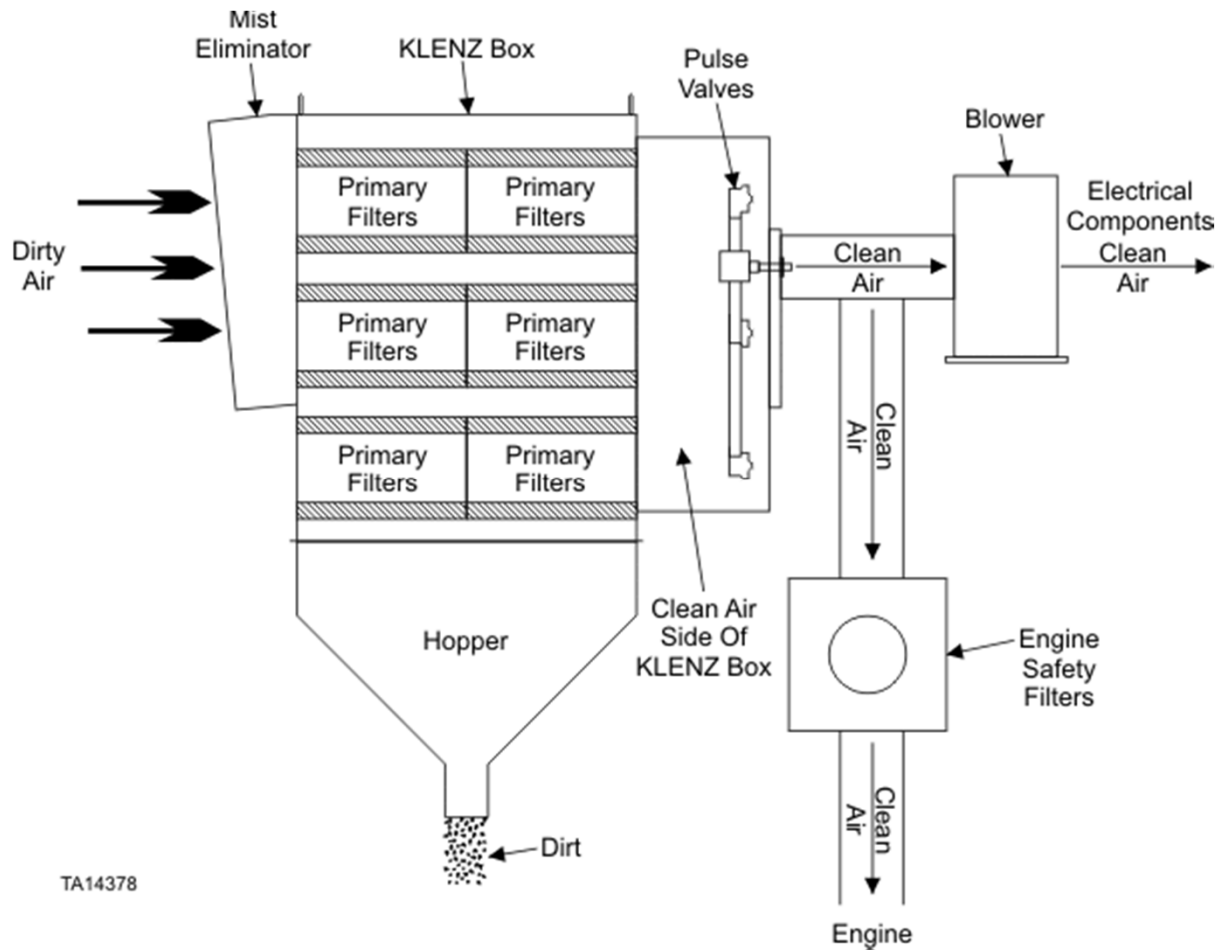

AIR SYSTEM KLENZ PULSE VALVE



AIR SYSTEM PULSE VALVE OPERATION

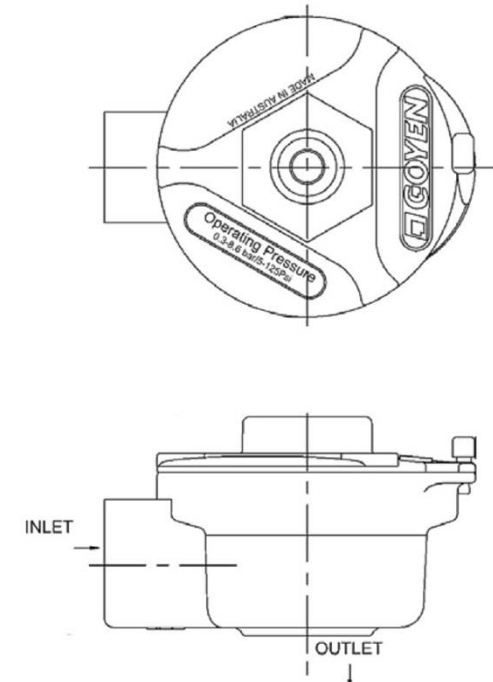
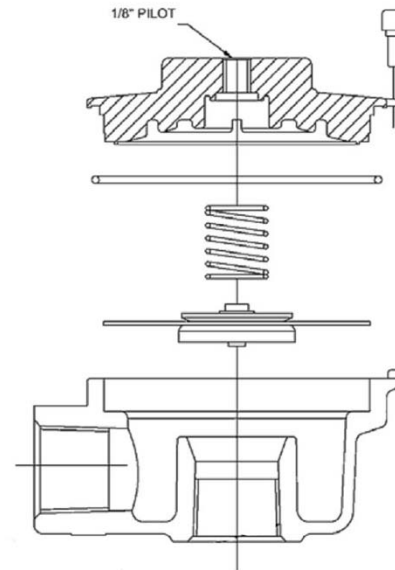
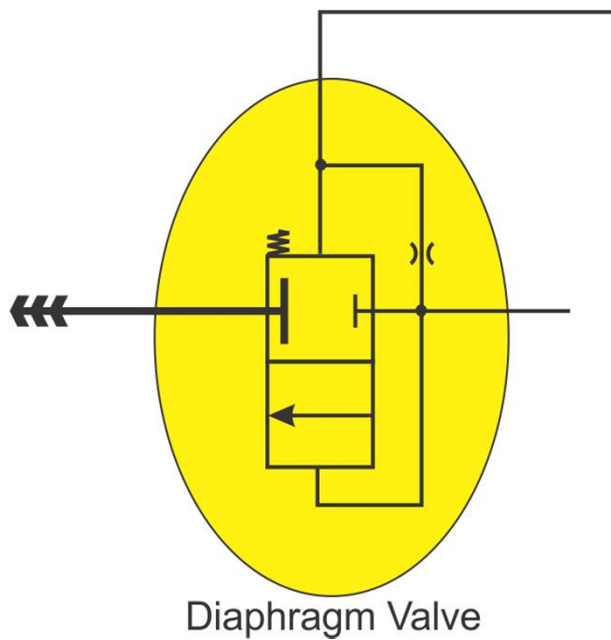

KLENZ MANIFOLD

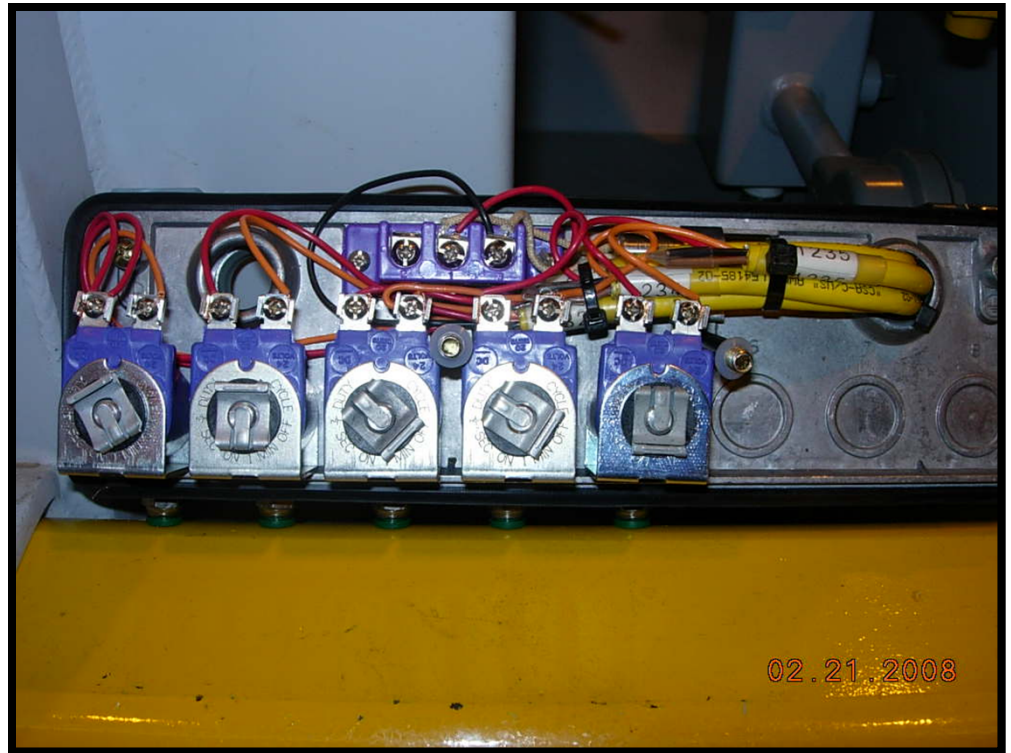

SERVICE PARTS

PARTS



SOL



CIRCUIT DESCRIPTIONS

SEE SCHEMATICS BOOK

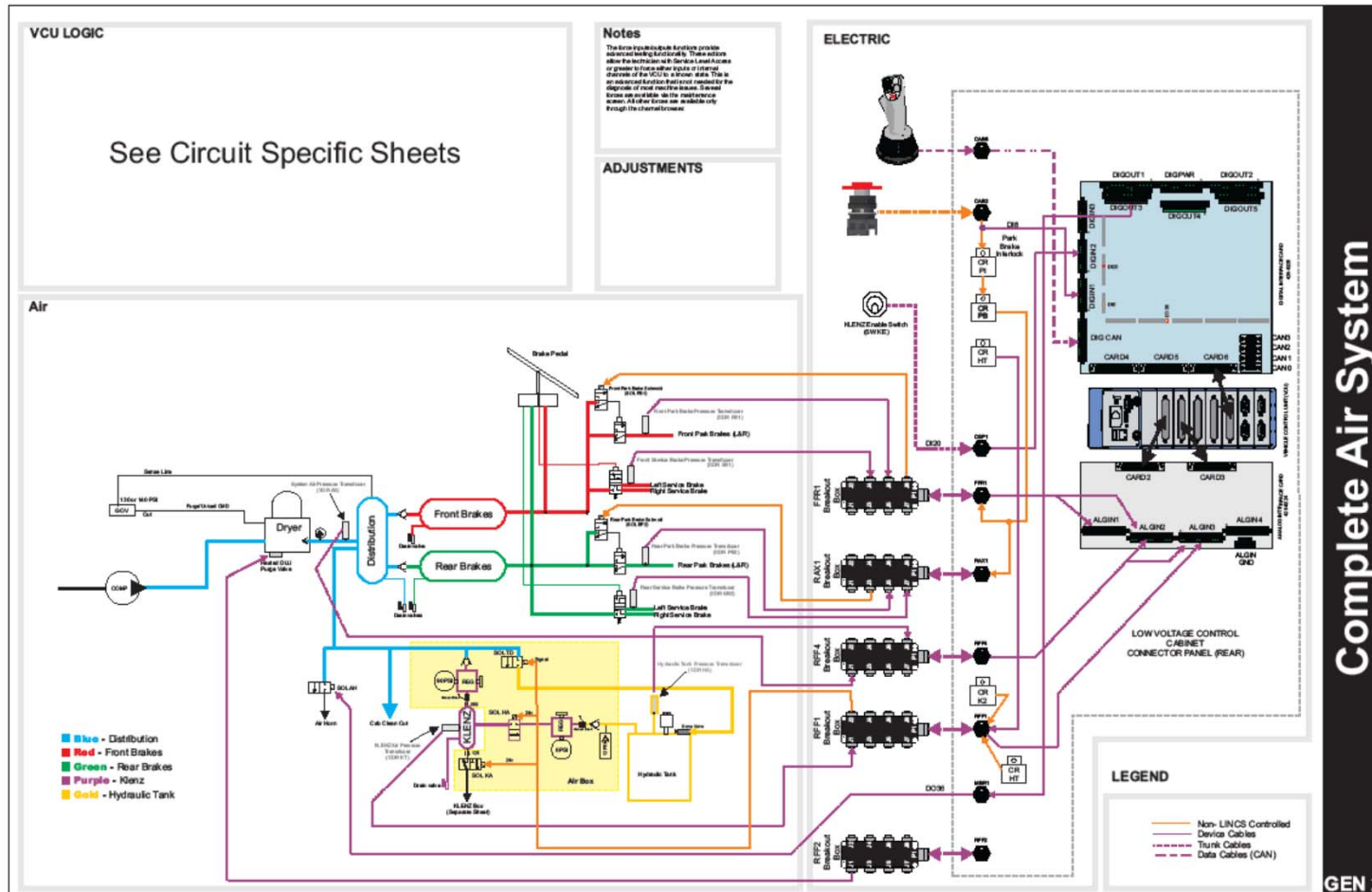

SEE SCHEMATICS BOOK

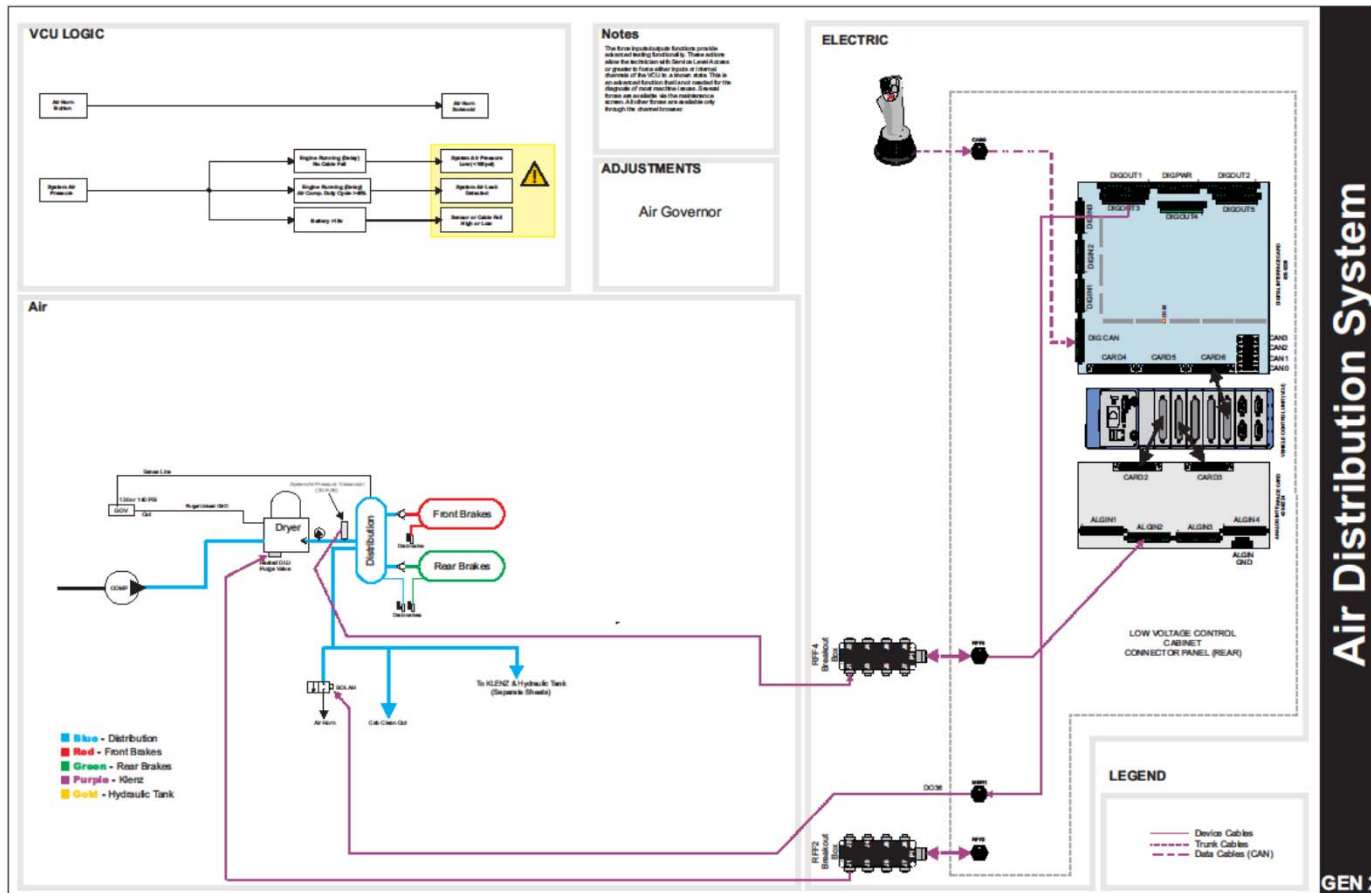

SEE SCHEMATICS BOOK

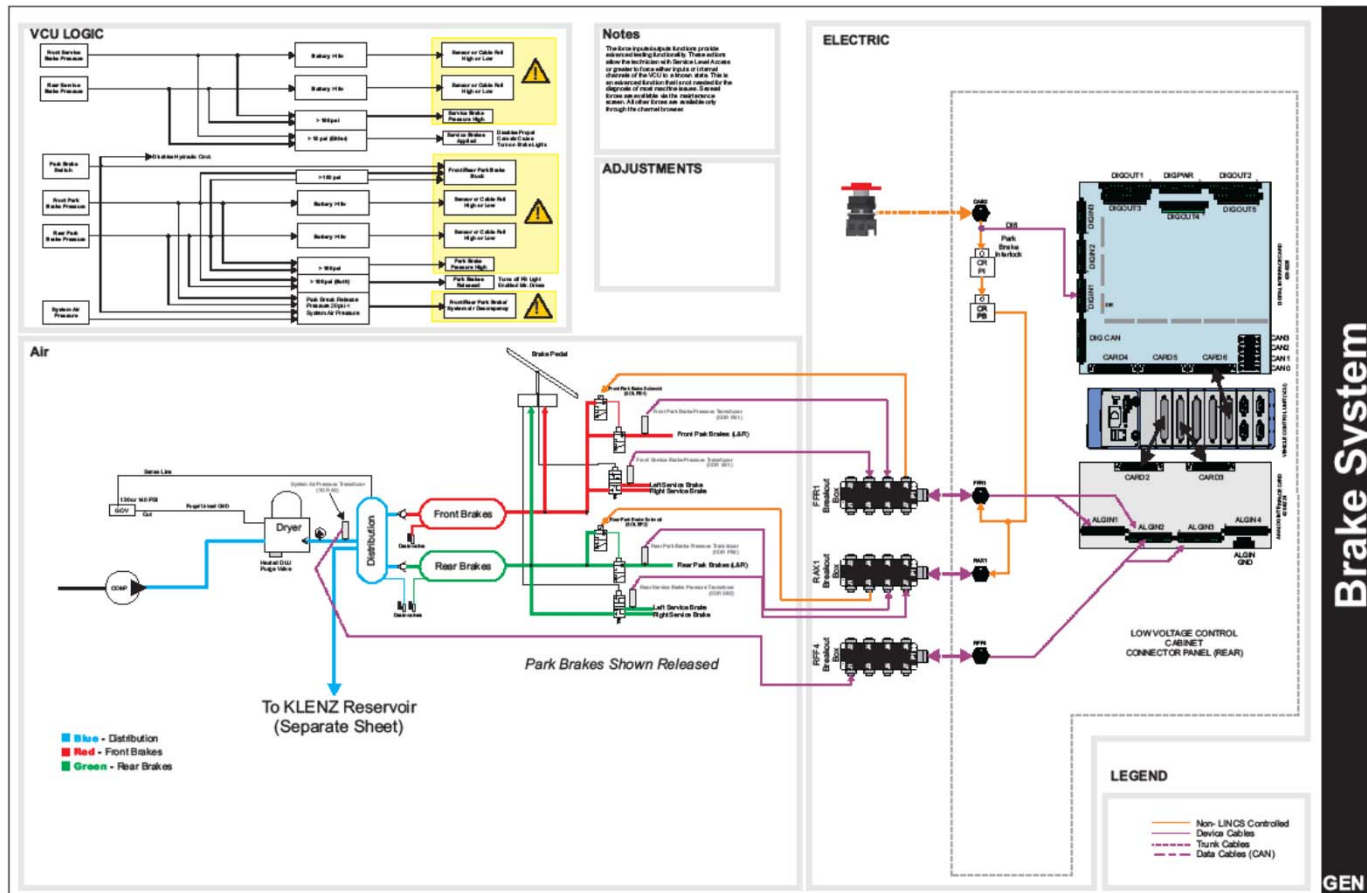

Brake System

SEE SCHEMATICS BOOK

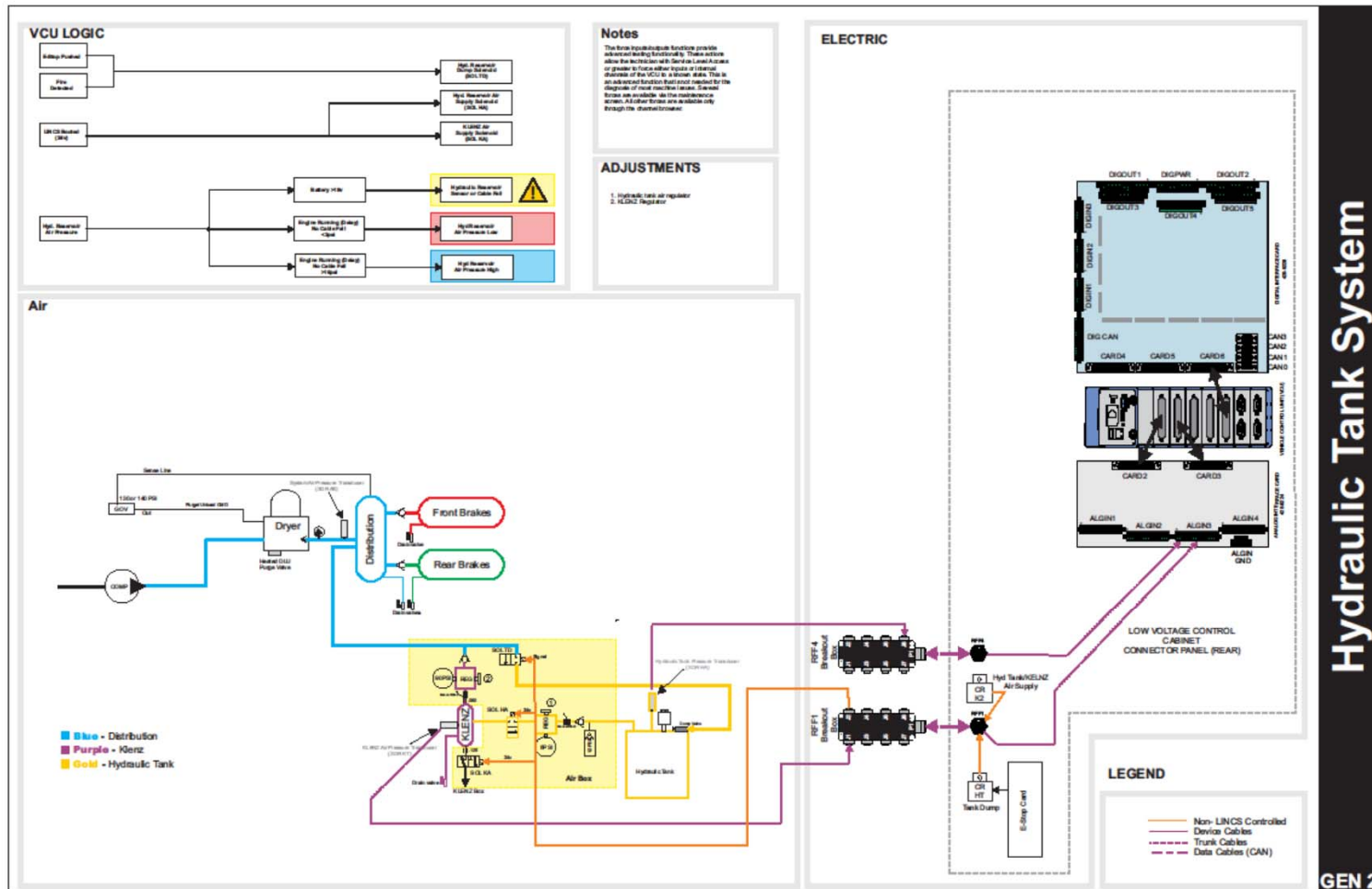

SEE SCHEMATICS BOOK

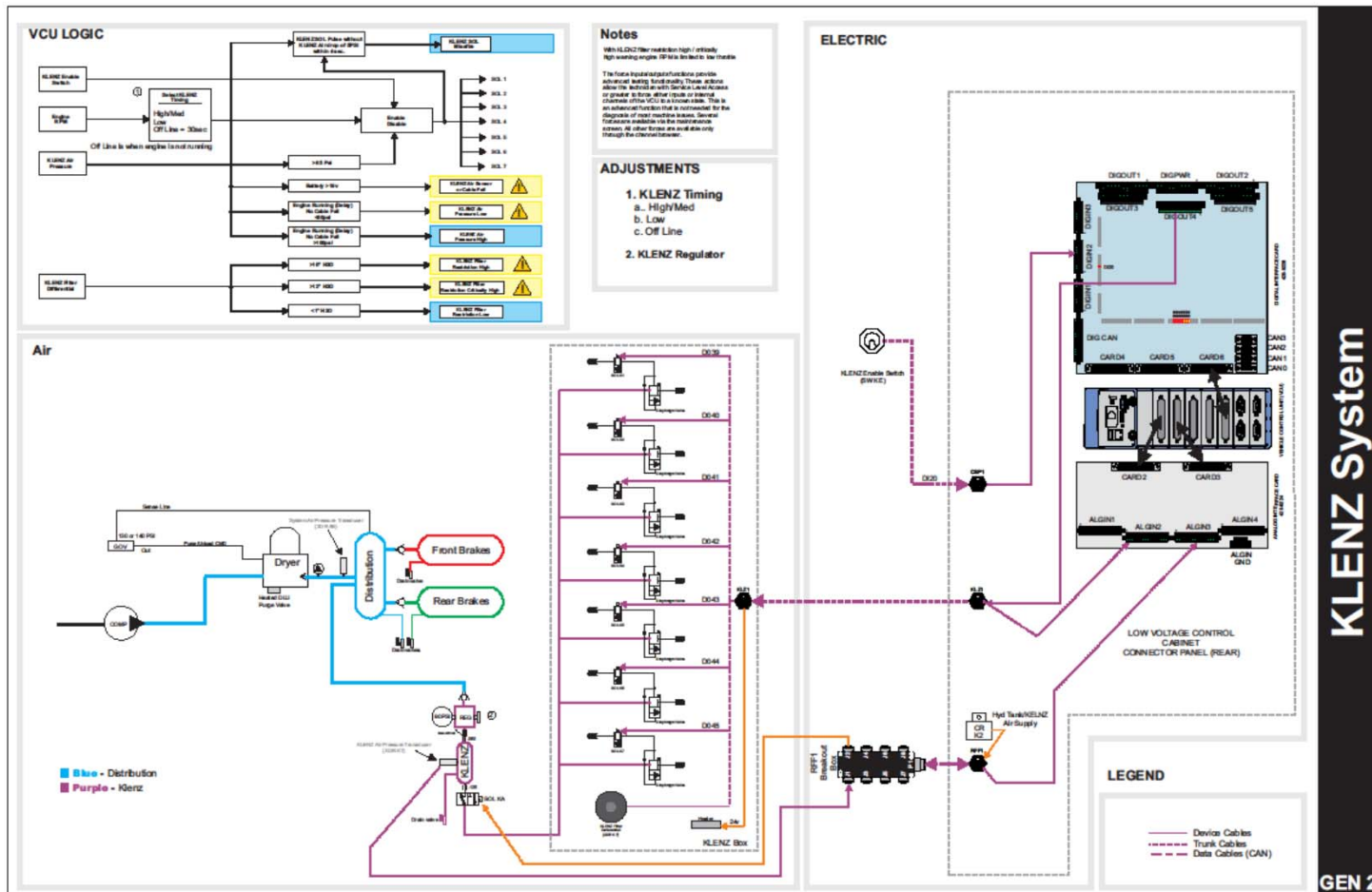

SETTINGS AND ADJUSTMENTS

SETTINGS AND ADJUSTMENTS

	L-950, L-1150, L-1350, L-1850	L-2350
Compressor Governor	130~135 psi	140~145 psi
Hydraulic Tank	4 to 6psi	4 to 6psi
Klenz System	90 psi	90 psi

AIR SYSTEM MAIN GOVERNOR SETTING

Adjustment of D-2 governor:

1. Remove the waterproof cap
2. Use a flat blade screwdriver to hold the adjusting screw.
3. Loosen the adjusting screw jam nut
4. To increase the pressure settings, turn the adjusting screw counter-clockwise
5. To decrease the pressure settings, turn the adjusting screw clockwise

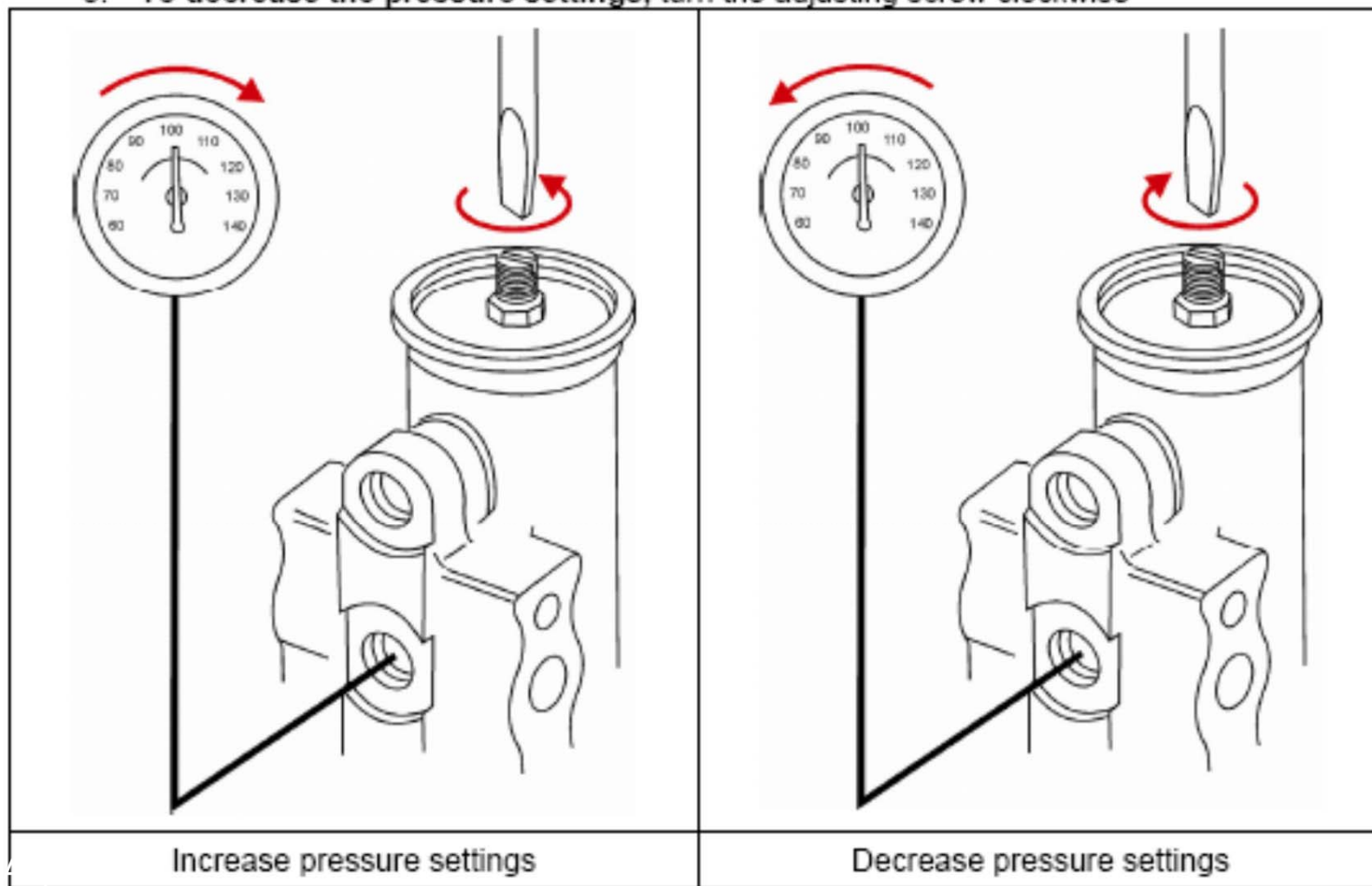

KLENZ AIR SYSTEM REGULATOR SETTINGS

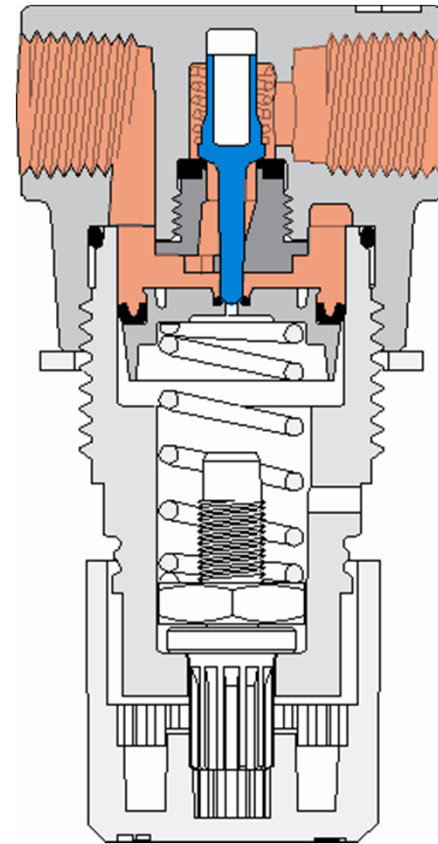
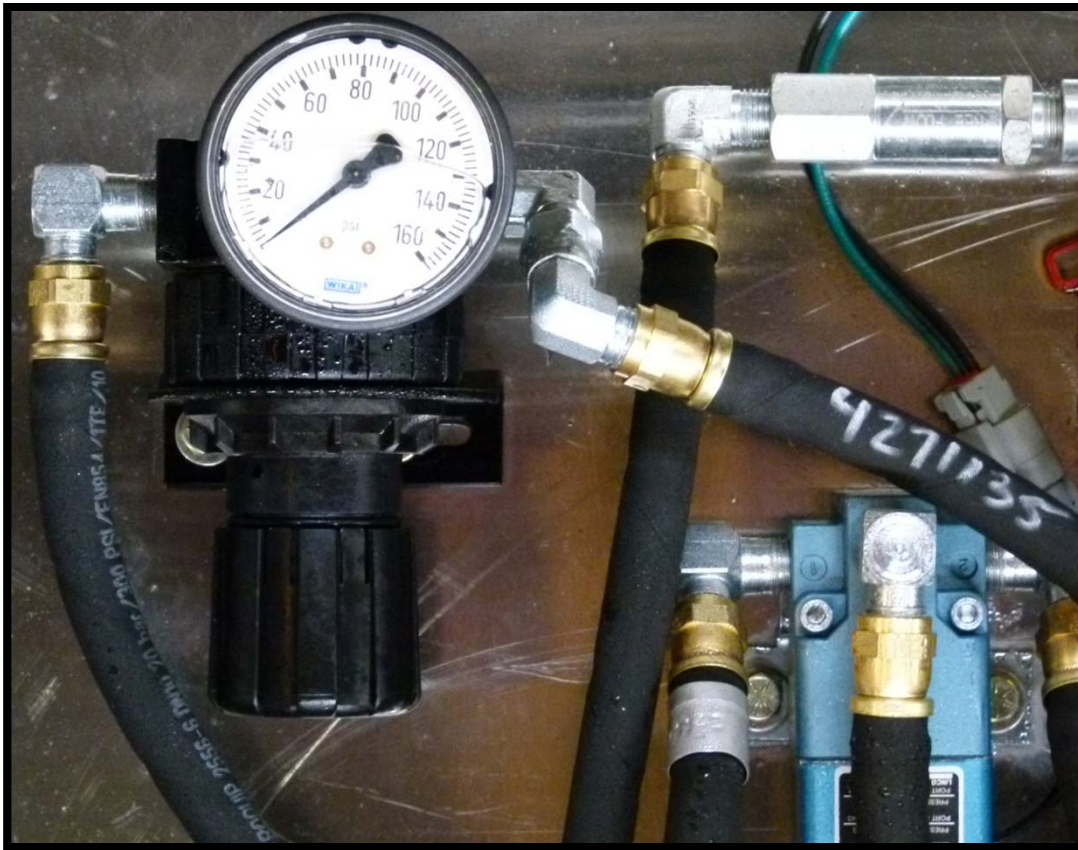

INSTALLATION AND REMOVAL

AIR SYSTEM BENDIX 922 BREAK DOWN

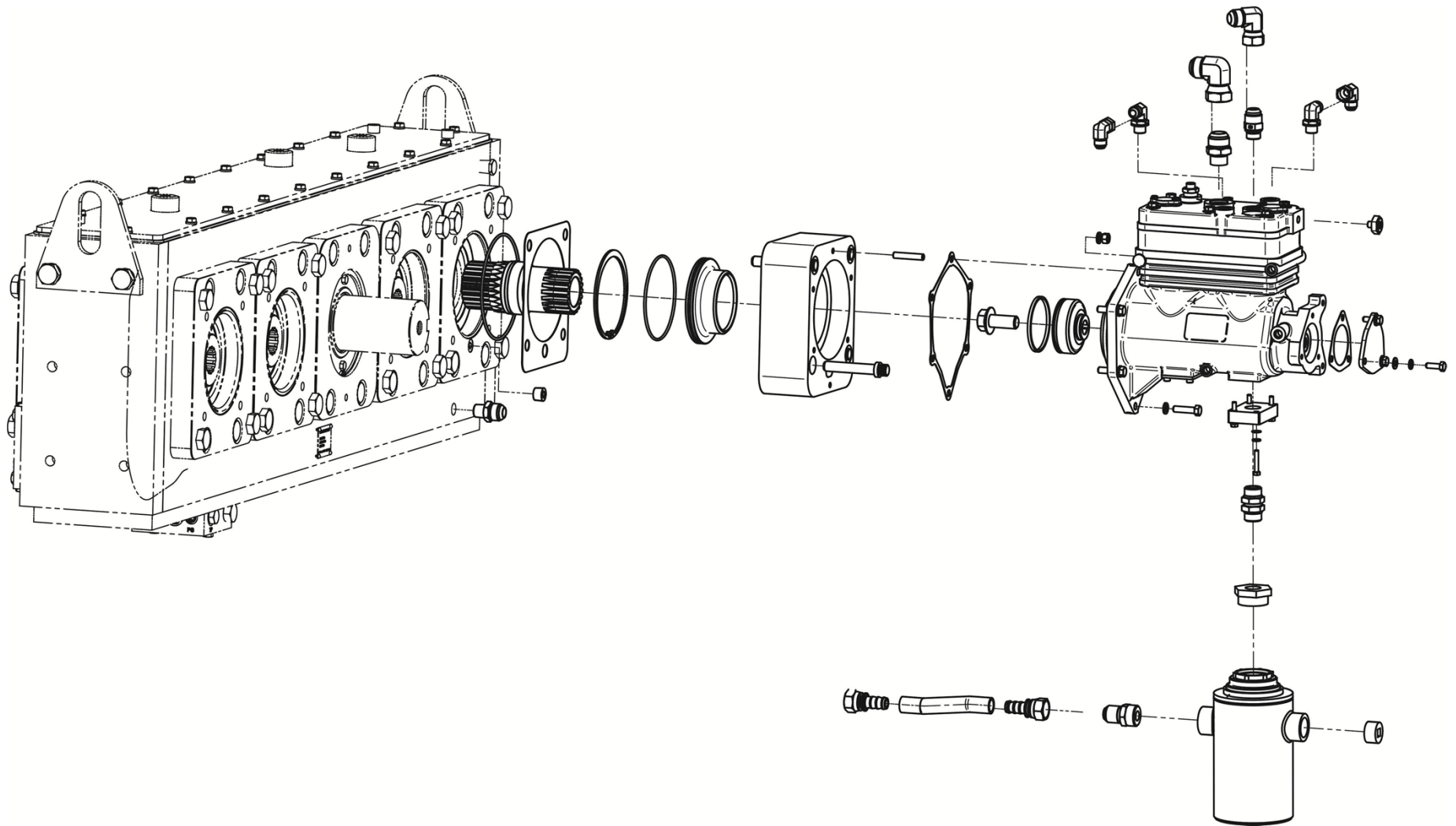

TROUBLESHOOTING